

# TM 9-1005-233-24

## DEPARTMENT OF THE ARMY TECHNICAL MANUAL

---

ORGANIZATIONAL, DIRECT SUPPORT  
AND GENERAL SUPPORT MAINTENANCE MANUAL  
INCLUDING REPAIR PARTS AND SPECIAL TOOLS LIST  
(INCLUDING DEPOT MAINTENANCE  
REPAIR PARTS AND SPECIAL TOOLS)

FOR

**MACHINE GUN, 7.62-MM, M73**

**(1005-869-8816)**

**MACHINE GUN, 7.62-MM, M73A1**

**(1005-937-7323)**

**MACHINE GUN, 7.62-MM, M219**

**(1005-077-2354)**

This copy is a reprint which includes current  
pages from Changes 1 through 5.  
FORMERLY BOUND

---

HEADQUARTERS, DEPARTMENT OF THE ARMY  
FEBRUARY 1972

## WARNING

Before starting an inspection, be sure to clear the weapon. Do not actuate the trigger until the weapon has been cleared. Inspect the chamber to insure that it is empty, and check to see that no ammunition is in position to be introduced.

## WARNING

In the event of a misfire the round will remain locked in the chamber for the prescribed time intervals. the gun trained on the target. and personnel cleared from the area.

## WARNING

Allow the weapon to cool at least five minutes before attempting to open cover assembly.

## WARNING

Do not retract the charger handle and allow it to go forward if belted ammunition is on the feed tray and a "live" round is in the chamber.

## WARNING

Keep weapon trained on target

## WARNING

Avoid skin contact with P-C-111b. The compound should be washed off thoroughly with running water if it comes in contact with the skin. A good lanolin base cream, after exposure to compound, is helpful. The use of rubber gloves and protective equipment is recommended.

## WARNING

Make certain that the barrel extension is in forward position to prevent injury to personnel.

## WARNING

Use the hand charger assembly handle to retract barrel extension assembly. Never use the hands.

Change }  
No. 5 }

HEADQUARTERS,  
DEPARTMENT OF THE ARMY  
WASHINGTON, D.C., 29 August 1973

**Organizational, Direct Support, and General Support**

**Maintenance Manual Including Repair Parts**

**and Special Tools List (Including Depot**

**Maintenance Repair Parts and Special Tools)**

**MACHINE GUN, 7.62-MM, M73  
(1005-869-8816)**

**MACHINE GUN, 7.62-MM, M73A1  
(1005-937-7323)**

**MACHINE GUN, 7.62-MM, M219  
(1005-077-2354)**

TM 9-1005-233-24, 9 February 1972, is changed as follows:

*Page 18.* Paragraphs 2-8 e(1) (a) and 2-8 e(2) (b).  
Delete the statement "wait five seconds in the  
event of a hangfire."

In the warning under paragraph 2-8 e(2) (d).  
change "five" to "fifteen."

By Order of the Secretary of the Army:

**CREIGHTON W. ABRAMS**  
*General, United States Army*  
*Chief of Staff.*

**Official:**

**VERNE L BOWERS,**  
*Major General, United States Army,*  
*The Adjutant General.*

**Distribution:**

To be distributed in accordance with DA Form 12-40 (qty rqr block No. 104) Organizational Maintenance requirements for Machine Gun, 7.62 MM, M73 Tank.

Change }  
No. 4 }

HEADQUARTERS  
DEPARTMENT OF THE ARMY  
Washington, D. C., 21 June 1973

**Organizational, Direct Support, and General Support  
Maintenance Manual Including Repair Parts  
and Special Tools List (Including Depot)  
Maintenance Repair Parts and Special Tools)**

**MACHINE GUN, 7.62-MM, M73  
(1005-869-8816)  
MACHINE GUN, 7.62-MM, M73A1  
(1005-937-7323)  
MACHINE GUN, 7.62-MM, M219  
(1005-077-2354)**

TM 9-1005-233-24, 9 February 1972, is changed as follows

Page 15. Add the following statement to paragraph 2-7:

This organizational maintenance function applies to the general condition of the weapon on a quarterly basis (each 90 days) or more frequently if the condition of the equipment warrants it.

Page 32. Add the following statement to paragraph 2-12 b:

This organizational maintenance function is performed prior to and/or after firing/cleaning and re-lubrication.

Page 58. Change Maintenance Allocation Chart as follows: Under (3) maintenance functions, column 1 (Inspect), change all C's to 0 and all manhours to 0.1.

By Order of the Secretary of the Army:

Official:

**VERNE L. BOWERS**  
Major General, United States Army  
*The Adjutant General*

**CREIGHTON W. ABRAMS**  
*General, United States Army*  
*Chief of Staff*

Distribution:

To be distributed in accordance with DA Form 12-40 (qty rqr block No. 104). Organizational maintenance requirements for Machine Gun, 7.62 MM, M73 Series.



CHANGE

No. 3

}

HEADQUARTERS  
DEPARTMENT OF THE ARMY  
WASHINGTON, D.C., 5 April 1973

**Organizational, Direct Support, and General Support Maintenance Manual**

**Including Repair Parts and Special Tools List**

**(Including Depot Maintenance**

**Repair Parts and Special Tools)**

**MACHINE GUN 7.62-MM M73**

**(1005-869-8816)**

**MACHINE GUN 7.62-MM M73A1**

**(1005-937-7323)**

**AND**

**MACHINE GUN 7.62-MM M219**

**(1005-077-2354)**

TM 9-1005-233-24, 9 February 1972, is changed as follows:

*Page 67, figure C-4, item 1.* Change FSN from 1005-950-0790 to 1005-003-1073. Change reference number from 11013395 to 8448780.

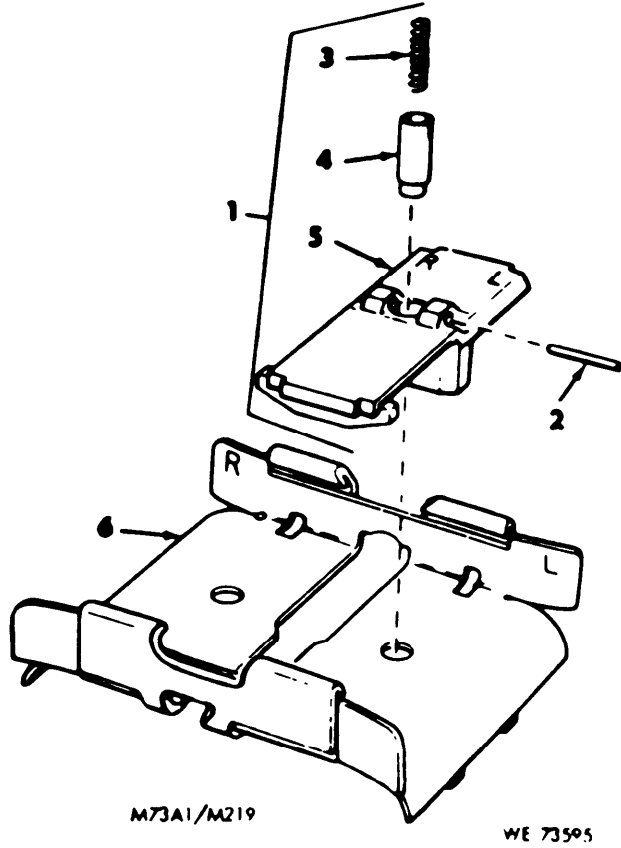
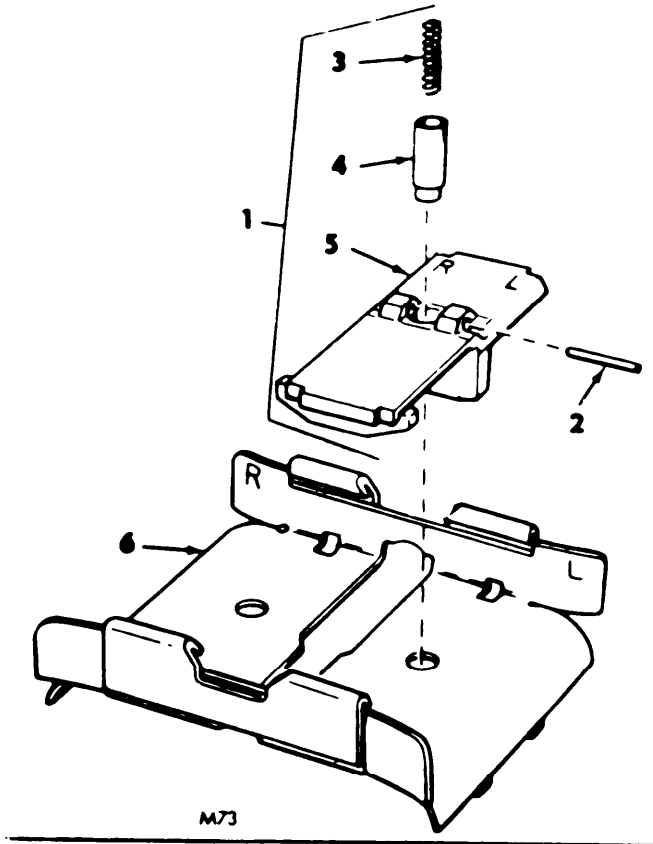

Figure C-4. Feed tray group-exploded view.



*Page 92* Delete stock number 1005-950-0790, figure No. C-4, Item No. 1 Add stock number 1005-003-1073, figure No C-4, item No. 1.

*Page 94* Delete reference number 11013395, mfg code 19204, fig. No. C-4, Item No. 1.

*Page 95* Add reference number 8448780, mfg code 19204, fig. No. C-4, item No. 1

By Order of the Secretary of the Army:

CREIGHTON W. ABRAMS  
*General, United States Army*  
*Chief of Staff*

Official:

VERNE L. BOWERS  
*Major General, United States Army*  
*The Adjutant General*

Distribution:

To be distributed in accordance with DA Form 12-40, (qty rqr block No. 104) Organizational Maintenance Requirements for Machine Gun, 7.62-MM, M73 (Tank).

CHANGE }  
No. 2 }

HEADQUARTERS  
DEPARTMENT OF THE ARMY  
WASHINGTON, D. C., 5 January 1973

**Organizational, Direct Support and  
General Support Maintenance Manual  
Including Repair Parts and Special Tools List  
(Including Depot Maintenance  
Repair Parts and Special Tools)  
MACHINE GUN 7.62-MM M73  
MACHINE GUN 7.62-MM M73A1  
AND  
MACHINE GUN 7.62-MM M219**

TM 9-1005-233-24, 9 February 1972, is changed as follows:

*Page 44.* Table 4-1, repair column. Change last sentence from, "Pin (4, fig C-10) will be staked in 2 places both sides after assembly" to "Pin in M73, M73A1, and M219 rammer (fig C-10) will be staked securely in two places, both sides."

*Page 45.* Table 4-1, inspection column. Change first sentence from, "Check pin (4, fig C-10) for secure staking in 2 places, both sides" to "Check pin in M73, M73A1, and M21Q for secure staking in two places, both sides."

*Page 87.* Figure C-10 is superseded as follows:

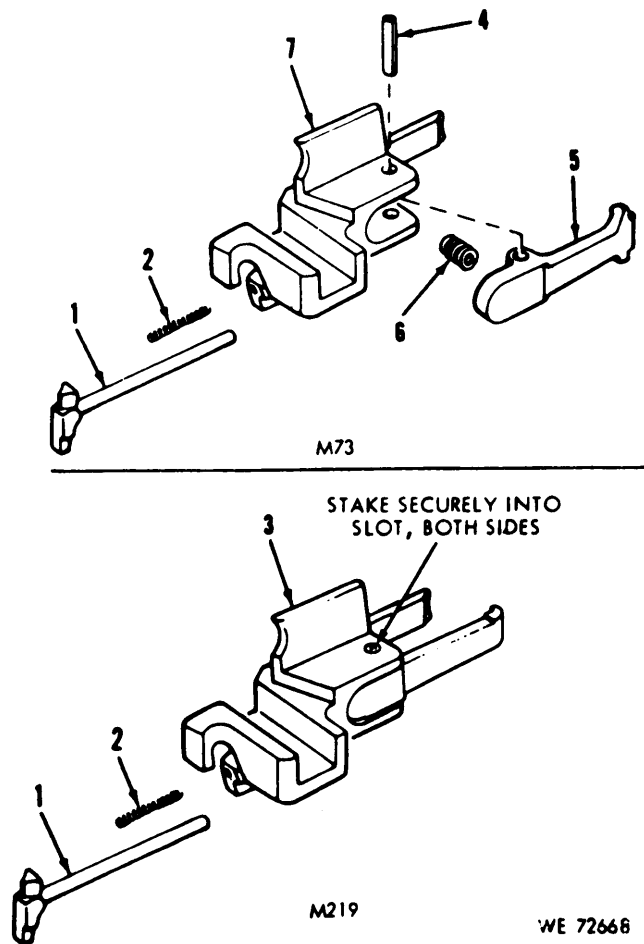

Figure C-10. Rammer assembly-exploded view.

By Order of the Secretary of the Army:

**CREIGHTON W. ABRAMS**  
**General, United States Army**  
*Chief of Staff*

Official:

**VERNE L. BOWERS**  
**Major General, United States Army**  
**The Adjutant General**

Distribution:

To be distributed in accordance with DA Form 12-40, (qty rqr block No. 104) Organizational maintenance requirements for Machine Gun, 7.62MM, M73 Tank.

Change

HEADQUARTERS  
DEPARTMENT OF THE ARMY  
Washington, D. C., 4 August 1972

No. 1

**Organizational, Direct Support and General Support Maintenance Manual  
Including Repair Parts and Special Tools List  
(Including Depot Maintenance Repair Parts and Special Tools)  
FOR  
MACHINE GUN, 7.62-MM, M73  
(1005-869-8816)  
MACHINE GUN, 7.62-MM, M73A1  
(1005-937-7323)  
MACHINE GUN, 7.62-MM, M219  
(1006-077-2354)**

TM 9-1005-233-24,9 February 1972, is changed as follows:

Page 44, table 4-1, repair column.

Line 18, delete "After assembly, hammer link (11, fig C-7) shall be staked at both ends" and substitute the following

To replace broken hammer retaining screw (9, fig C-7) observe the following procedures:

- a. Assemble hammer, link and retaining screw (but not the roller).
- b. Tighten screw to 80 in-lb + 20 in-lb torque.
- c. Using the .094 diameter hole in the link as a guide, drill a hole .094 + .003 in the new screw to accommodate spring pin (7, fig C-7).
- d. Disassemble hammer, link and screw.
- e. Assemble hammer, link, roller and screw. Tighten screw so hole in screw alines with holes in link. Roller shall rotate freely without binding.
- f. Assemble spring pin thru link and screw.

Page 45, table 4-1, inspection column.

Line 7, delete "Inspect link (11, fig C-7) for secure staking on both sides".

By Order of the Secretary of the Army:

BRUCE PALMER, JR.  
General U.S. Army  
Acting Chief of Staff

Official:

VERNE L. BOWERS,  
Major General *United States Army*,  
*The Adjutant General*.

Distribution:

To be distributed in accordance with DA Form 12-40 (qty rqr block no. 104), Organizational maintenance requirements for Machine Gun, 7.62-MM, M73 Series.





**ORGANIZATIONAL, DIRECT SUPPORT AND  
GENERAL SUPPORT MAINTENANCE MANUAL  
INCLUDING REPAIR PARTS AND SPECIAL TOOLS LIST  
(INCLUDING DEPOT MAINTENANCE  
REPAIR PARTS AND SPECIAL TOOLS)  
MACHINE GUN 7.62-MM M73  
MACHINE GUN 7.62-MM M73A1  
AND  
MACHINE GUN 7.62-MM M219**

*This manual is current as of 28 January 1972*

		Paragraph	Page	Illust fig
CHAPTER	1.	INTRODUCTION		
Section	I.	General . . . . .	1-1-5	5
	II.	Description and data . . . . .	1-6-1-10	5
CHAPTER	2.	ORGANIZATIONAL MAINTENANCE INSTRUCTIONS		
Section	I.	Service upon receipt of materiel . . . . .	2-1-2-2	11
	II.	Repair parts, special tools, and equipment . . . . .	2-3	14
	III.	Lubrication instructions . . . . .	2-4-2-6	14
	IV.	Preventive maintenance checks and services . . . . .	2-7	15
	V.	Troubleshooting . . . . .	2-8	16
	VI.	Organizational maintenance procedues . . . . .	2-9-2-12	21
CHAPTER	3.	DIRECT SUPPORT AND GENERAL SUPPORT MAINTENANCE INSTRUCTIONS		
Section	I.	Repair parts, special tools and equipment . . . . .	3-1	37
	II.	Troubleshooting . . . . .	3-2	37
	III.	Preembarkation inspection of materiel in units alerted for overseas movement. . . . .	3-3-3-4	39
	IV.	General maintenance . . . . .	3-5-3-6	40
CHAPTER	4.	REPAIR INSTRUCTIONS . . . . .	4-1-4-6	41
CHAPTER	5.	FINAL INSPECTION . . . . .	5-1-5-4	53
APPENDIX	A.	REFERENCES . . . . .	A-1-A-3	55
APPENDIX	B.	MAINTENANCE ALLOCATION CHART		
Section	I.	Introduction . . . . .	B-1-B-3	57
	II.	Maintenance allocation chart . . . . .		58

**\*This manual supersedes TM 9-1005-233-25, 25 May 1967, including all changes.**

		Paragraph	Page	Illust fig	
APPENDIX C .		ORGANIZATIONAL, DIRECT SUPPORT, AND GENERAL SUPPORT MAINTENANCE REPAIR PARTS AND SPECIAL TOOLS LIST (INCLUDING DEPOT MAINTENANCE REPAIR PARTS AND SPECIAL TOOLS)			
Section	<b>I.</b>	Introduction . . . . .	C-1-C-6	59	
	<b>II.</b>	Repair parts list . . . . .		62	
	<b>III.</b>	Special tools list . . . . .		63	
	<b>IV.</b>	Repair parts list . . . . .		65	
		Major Groups and assemblies . . . . .		80	C-1
		Jacket assembly w/beafing . . . . .		81	C-2
		Cover assembly . . . . .		82	C-3
		Feed tray group . . . . .		83	C-4
		Back plate assemblyw/solenoid . . . . .		84	C-5
		Breechblock assembly . . . . .		84	C-6
		Barrel extension assembly . . . . .		85	C-7
		Carrier assembly . . . . .		86	C-8
		Lever assembly . . . . .		86	C-9
		Rammer assembly . . . . .		87	C-10
		Charger assembly . . . . .		88	C-11
		Receiver assembly . . . . .		89	C-12
				90	C-13
	<b>V.</b>	Special tools liar . . . . .		77	C-14
	<b>VI.</b>	Federal stock number and reference number index . . . . .		92	



## LIST OF ILLUSTRATIONS

Number	Title	Page
1-1.	7.62-MM Machine Guns, M73, M73A1, and M219—right rearview. . . . .	6
1-2.	Difference between models-barrel extension assemblies. . . . .	8
1-3.	Differences between models . . . . .	9
2-1.	7.62-MM Machine Gun M73 assembled for right and left hand feed. . . . .	13
2-2.	Removal of ruptured cartridge case, live round, or empty case. . . . .	17
2-3.	Removal /installation of flash hider. . . . .	22
2-4.	Disassembly /assembly of machine gun. (1 of 4) . . . . .	25
2-5.	Disassembly /assembly of machine gun. (2 of 4) . . . . .	26
2-6.	Disassembly /assembly of machine gun. (3 of 4) . . . . .	27
2-7.	Disassembly /assembly of machine gun. (4 of 4) . . . . .	28
2-8.	Disassembly /assembly of cover assembly. (1 of 2) . . . . .	29
2-9.	Disassembly/assembly of cover assembly. (2 of 2) . . . . .	30
2-10.	Disassembly /assembly of receiver assembly. . . . .	31
4-1.	Forming nut shield . . . . .	47
4-2.	Replacing trigger safety pin 11013429. . . . .	48
4-3.	Preloading buffer assembly . . . . .	48
4-4.	Checking height of sear hooks. . . . .	49
4-5.	Repair of shell assembly . . . . .	50
4-6.	Repair of cover and track assembly. . . . .	51
C-1.	Machine Guns, 7.62-MM, M73, M73A1, and M219, major groups and assemblies-partial exploded view . . . . .	80
C-2.	Jacket assembly w/bearing—exploded view. . . . .	81
C-3.	Cover assembly—exploded view. . . . .	82
C-4.	Feed tray group—exploded view . . . . .	83
C-5.	Back plate assembly w/solenoid—exploded view. . . . .	84
C-6.	Breechblock assembly—exploded view . . . . .	84
C-7.	Barrel extension assembly—exploded view . . . . .	85
C-8.	Carrier assembly—exploded view. . . . .	86
C-9.	Lever assembly—exploded view. . . . .	86
C-10.	Rammer assembly—exploded view. . . . .	87
C-11.	Charger assembly—exploded view. . . . .	88
C-12.	Receiver assembly (M73 and M73A1 only)—exploded view . . . . .	89
C-13.	Receiver assembly (M219 only)—exploded view. . . . .	90
C-14.	Tools and equipment . . . . .	91

## LIST OF TABLES

Number	Title	Page
1-1	Major Groups and Assemblies . . . . .	6
2-1	Service Upon Receipt of Materiel. . . . .	11
2-2	Equipment Conversion—Feed Direction . . . . .	12
2-3	Equipment Conversion—Charger Assembly . . . . .	13
2-4	Maintenance Supplies and Materials . . . . .	14
2-5	Organizational Preventive Maintenance Checks and Services . . . . .	16
2-6	Organizational Troubleshooting . . . . .	19
2-7	Disassembly /Assembly of Machine Guns . . . . .	23
2-8	Detailed Cleaning Procedures . . . . .	31
2-9	Organizational Maintenance Procedures . . . . .	33
3-1	Direct and General Support Troubleshooting . . . . .	37
3-2	Preembarkation Inspection . . . . .	40
4-1	Repair Instructions for Machine Gun . . . . .	42
5-1	Final Inspection . . . . .	53



# CHAPTER 1

## INTRODUCTION

---

### Section I. GENERAL

#### 1-1. Scope

This manual contains instructions for organizational, direct support and general support maintenance maintaining the 7.62-mm Machine Guns, M73, M73A1, and M219 as allocated by the Maintenance Allocation Chart (appendix B).

##### NOTE

The model designation for the 7.62-mm Machine Gun M73E1 was changed to M73A1 and later changed to M219. All M73, M73E1 and M73A1 models will be changed at time of overhaul to the M219 configuration.

##### NOTE

Where the term "machine gun" is used, all information is applicable to all models. Where information is peculiar to only one model, the model designation, usable on code, etc., will be used for clarification.

#### 1-2. Forms and Records

Maintenance forms, records, and reports which are to be used by maintenance personnel at all

maintenance levels are listed in and prescribed by TM 38-750.

#### 1-3. Equipment Serviceability Criteria

The 7.62-MM Machine Guns M73, M73A1, M219 are used as mounted (fixed) vehicular guns. Equipment serviceability criteria (ESC) for the machine guns are found in the various vehicle ESC manuals, as the guns relate to the overall criteria for the vehicle.

#### 1-4. Destruction of Army Materiel to Prevent Enemy Use

Refer to TM 750-244-7.

#### 1-5. Reporting of Errors

Report of errors, omissions, and recommendations for improving this publication by the individual user is encouraged. Reports should be submitted on DA Form 2028, Recommended Changes to Publications and forwarded direct to, Commanding General, US Army Weapons Command, ATTN: AMSWE-MAP, Rock Island, Illinois 61201.

### Section II. DESCRIPTION AND DATA

#### 1-6. Description

The 7.62-mm Machine Guns M73, M73A1, and M219 (figure 1-1) are lightweight, air-cooled, metallic link belt fed from either right or left side, designed as a coaxial gun for tanks and 7.62-mm fire power on lighter armored vehicles. All have short receivers, are recoil operated with a gas assist to boost recoil and are designed with a quick

change barrel with fixed headspace. The cycle of operation and functioning is initiated from the retracted (seared) position of the barrel extension assembly. These machine guns can be easily disassembled. Major groups and assemblies are illustrated in figure C-1 and briefly described in table 1-1.

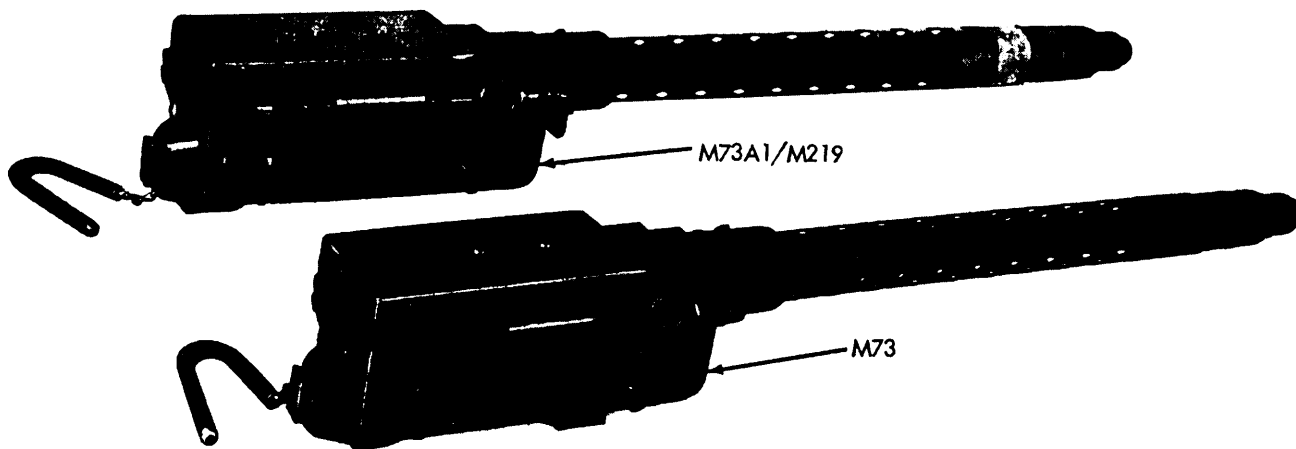

WE 63354A

Figure 1-1. 7.62-MM Machine Guns, M73, M73A1, and M219—right front view.

Table 1-1. Major Groups and Assemblies

Assembly or group	Reference	Description and location
Jacket assembly with bearing group	1 thru 4, fig C-1	Secured to front portion of the receiver assembly (trunnion block). Designed for quick removal. Consists of jacket assembly with bearing, lock and barrel assembly.
Cover assembly	5, fig C-1	Located on top of the receiver over the feed tray group. Secured to the receiver by the right and left latch rod assemblies. It feeds the belt and positions and holds the cartridges for cambering. The feed mechanism is actuated by a stud on the barrel extension which engages the feed cam.
Feed tray group	6, fig C-1	Located on top of receiver assembly under the cover assembly. It is composed of the cartridge stop assembly and the feed tray assembly. The feed tray group serves as a guide for the belt to assist in positioning the cartridges and provides directional control for link ejection. The M73A1 and M219 utilize a cartridge feed tray which has been redesigned by adding fixed ejectors to the bottom rear of the feed tray.
Back plate assembly, driving springs, and guide rod group	7 thru 10 fig C-1	Driving springs are located at rear of the barrel extension assembly. They are retained in position by the guide rods which are secured to the back plate. They help absorb recoil shock and provide the energy to feed, strip, chain her, and fire the following round. The back plate assembly is located at the rear portion of the receiver assembly. It houses the trigger, sear and solenoid. The trigger safety is located at the top of the back plate. It acts as a positive sear block for manual operation of the trigger and also when the weapon is operated by the solenoid. The back plate assembly contains a nut shield covering the nuts securing the solenoid to the back plate.
Barrel extension group	11 thru 13 fig C-1	The action group of the weapon. Composed of the breech block assembly and barrel extension assembly. This group chambers and fires the cartridge, locks and

Table 1-1. Major Groups and Assemblies-Continued

Assembly or group	Reference	Description and location
Barrel extension group-Continued  Charger group	14 thru 17 fig C-1	unlocks the breech, and extracts and ejects the spent cartridge cases.  Composed of a retaining ring, charger assembly and charger stud (M73A1 and M219 only). The retaining ring secures the charger assembly to the receiver. The charger assembly for the M73 Machine Gun may be assembled on the right or left side of the receiver by repositioning the slide connector and buffer pivot pin. In the M73A1 and M219 the charger assembly may be assembled on the right or left by repositioning the slide connector, buffer pivot pin, and charger mounting stud. The charger is utilized to manually charge the weapon (before loading), loading the first round, and to recharge the weapon in case of a malfunction or stoppage.
Receiver assembly	18, fig C-1	Serves as a support for all major assemblies and groups. It houses the action of the weapon and through a series of cam ways, controls the functioning of the barrel extension assembly, breech-block assembly, and buffer assembly.

### 1-7. Differences Between Models

a. The general appearance of the Machine Guns M73, M73A1, and M219 (fig 1-1) are alike; however, certain dissimilarities are visually apparent. The major changes occur in the barrel extension assembly (fig 1-2). A careful inspection of the M73A1 and M219 reveals the absence of the carrier assembly, the link assembly, and a spring pin. These three components have been eliminated. The lever assembly has been changed in the lever itself.

#### CAUTION

**Barrel extension assembly 11013360 (M73) is not interchangeable with barrel extension assembly 11013432 (M73A1 / M219). To interchange these assemblies will result in a malfunction. However, the basic barrel extension itself 11013350 is interchangeable.**

b. The variances between the M73, M73A1, and M219 are:

(1) The replacement of the stationary studs, fixed on both sides of the receiver, with a milled slot in either side of the M73A1 or M219 to accommodate the movable charger mounting stud (1, fig 1-3).

(2) The elimination of the ejector shield on the bottom of the M73 receiver. The M73A1 and

M219 are equipped with a spent case deflector plate on the lower right side of the receiver (2, fig 1-3).

(3) The redesign of the feed tray assembly by adding fixed ejectors to the bottom rear of the tray (3, fig 1-3).

(4) The redesign of the lever assembly by eliminating the case grip assembly and link assembly, and by redesigning the lever itself (4, fig 1-3).

(5) The redesign of the extractor, rammer, and rammer assembly (5, fig 1-3).

(6) The redesign of the buffer assembly (6, fig 1-3).

(7) The addition of new cams to the M219 receiver which alter the timing of extraction, ejection and ramming, and reduce the incidence of stoppages (32 and 33, fig C-13).

c. By the removal and redesign of the above interior parts, the stoppage rate is decreased. Maintenance requirements for the three models of the machine guns are similar except for minor variations due to the elimination and redesign of these parts. The machine guns can be interchanged as required for vehicular use. The mounting, zeroing, boresighting, and operating procedures are the same, and are found in the pertinent vehicle operators manual.

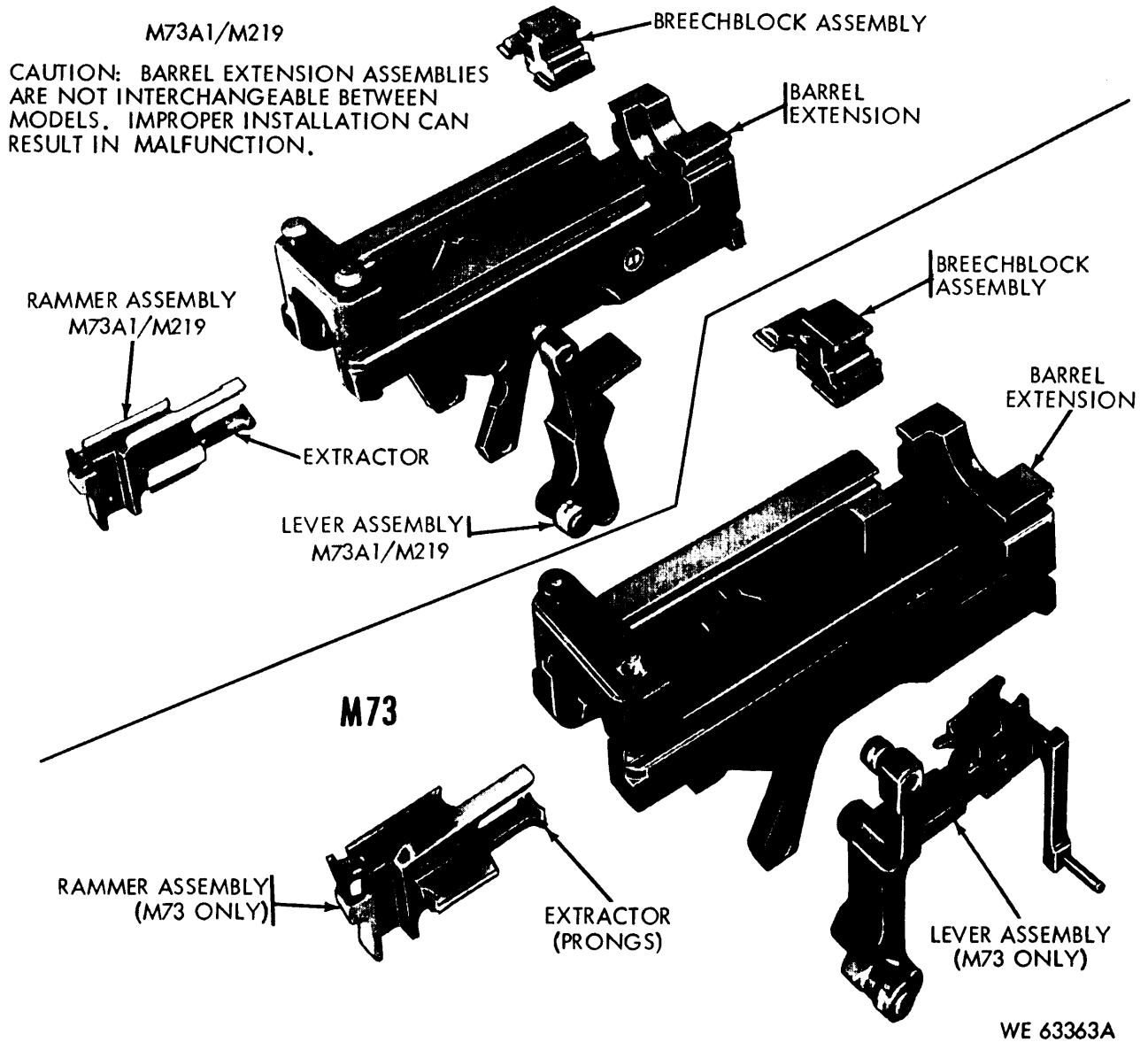
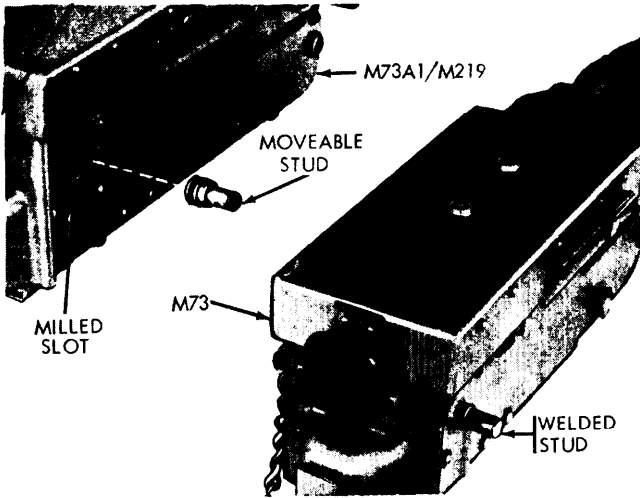
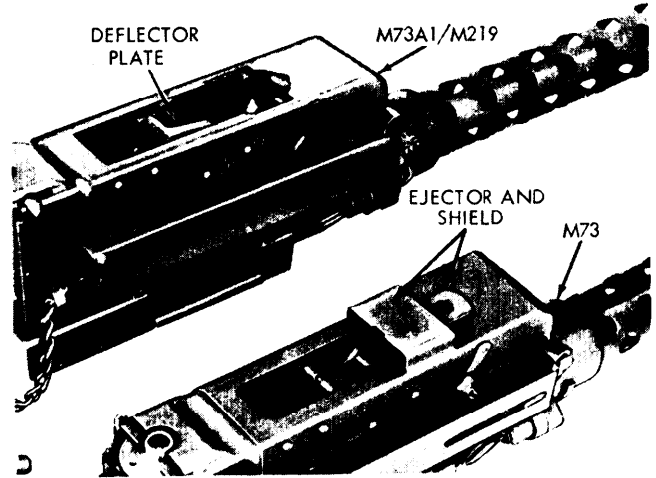

Figure 1-2. Differences between models—barrel extension assemblies.



1. CHARGER MOUNTING STUDS.



2. RECEIVER SHELL ASSEMBLIES - BOTTOM VIEW.

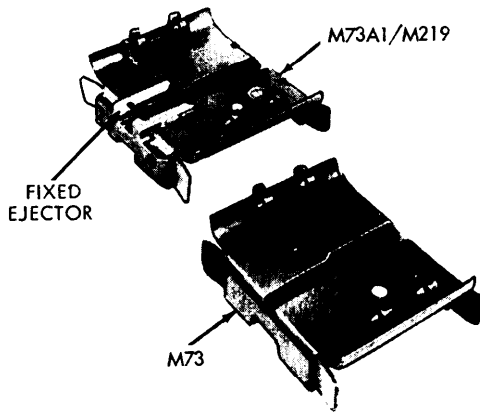

3. FEED TRAY ASSEMBLIES.

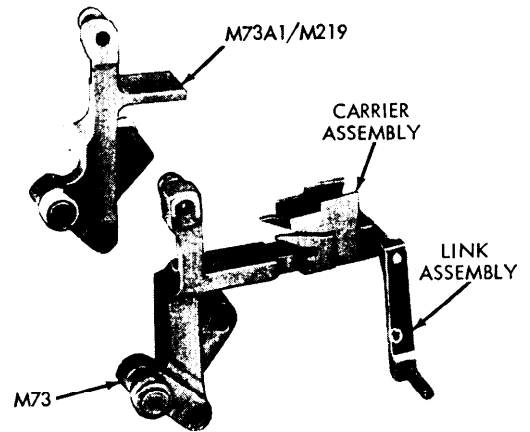

4. LEVER ASSEMBLIES.

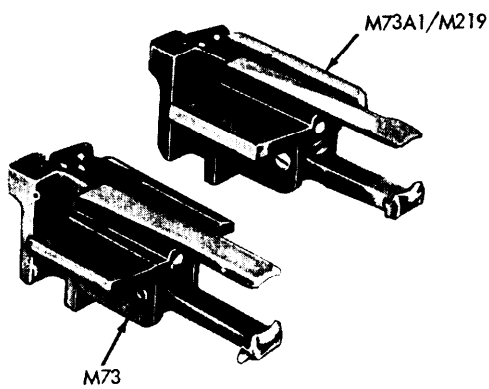

5. RAMMER ASSEMBLIES.

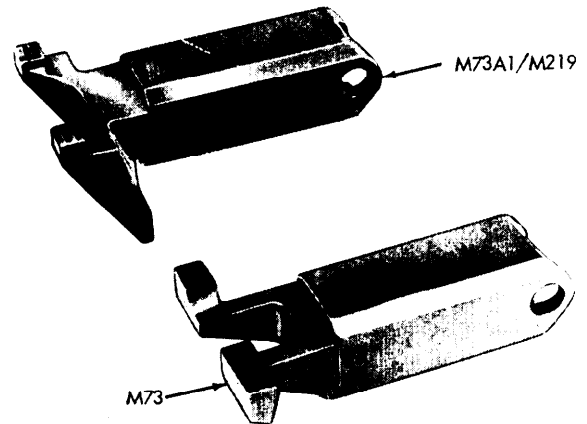

6. RECOIL MECHANISM BUFFER AND BUFFER ASSEMBLY.

WE 65490

Figure 1-3. Differences between models.

**1-8. Tabulated Data**

<i>Characteristic</i>	<i>M73</i>	<i>M73A1/M219</i>
Weight of gun	31.00 lbs	29.80 lbs
Weight of barrel	5.25 lbs	5.25 lbs
Length of gun	35.00 in	35.00 in
Length of barrel	22.00 in	22.00 in
Length of rifling	20.00 in (approx)	20.00 in (approx)
Number of grooves	4	4
Twist, right hand	One turn in 12 in	One turn in 12 in
Height, Cover closed	5.30 in	5.30 in
Height, Cover opened	6.60 in	6.60 m
Width	4.40 in	4.40 in
Feed	Metallic link belt (right or left hand)	Metallic link belt (right or left hand)
Operation	Recoil with gas assist	Recoil with gas assist
Cooling	Air	Air
Muzzle velocity	2,800 fps (approx)	2,800 fps (approx)
Rate of fire (cyclic)	500 to 625 rd per minute	500 to 625 rd per minute
Maximum range	See appropriate F.T. (approx 3,700 meters or 4,150 yards)	See appropriate F. T. (approx 3,700 meters or 4,150 yards)
Maximum effective range	900 meters (tracer burnout point)	900 meters (tracer burnout point)
Method of target engagement	20-30 round bursts	20-30 round bursts

**1-9. Identification Markings**

The model number and serial number of the mathine gun is located on the left side of the receiver.

**1-10. Administrative Storage**

Refer to TM 740-90-1.



## CHAPTER 2

# ORGANIZATIONAL MAINTENANCE INSTRUCTIONS

### Section I. SERVICE UPON RECEIPT OF MATERIEL

#### 2-1. General

Refer to table 2-1 for instructions on servicing the machine guns after initial receipt.

*Table 2-1. Service Upon Receipt of Materiel*

Step	Action	Reference
	<b>WARNING</b>	
	<b>Before starting an inspection, be sure to clear the weapon. Do not actuate the trigger until the weapon has been cleared. Inspect the chamber to insure that it is empty, and check to see that no ammunition is in position to be introduced.</b>	
1.	Remove gun and items from containers.	
2.	Check for missing items.	
	<b>NOTE</b>	
	Items must agree with Basic Issue Items List.	Refer to appendix area of pertinent vehicle operator's manual for Basic Issue Items List.
3.	Remove VCI (volatile corrosion inhibitor) bore tube from barrel, and clean bore with clean, dry cleaning swabs.	
4.	Wipe off excess oil and clean with a lintless cloth.	
5.	Field strip and inspect for: Missing or damaged parts. Proper assembly (note direction of feed; for conversion refer to paragraph 2-2),	
	<b>CAUTION</b>	
	<b>Check to make sure the proper barrel extension assembly is installed, and accompanying the weapons, as spare parts.</b>	Para 1-7.
6.	Clean and lubricate.	Para 2-4, 2-5, 2-6, and 2-12a.
7.	Install flash hider or flash suppressor as required by the vehicle application where the machine gun is to be used.	
8.	Re-assemble.	
9.	Function, using belted dummy cartridges.	

#### 2-2. Conversion of Equipment

a. *Changing Direction of Ammunition Feed.* The machine gun is normally issued and used as a left hand fed weapon. However, some vehicle applications use the gun with right hand feed. The

following conversion instructions in table 2-2 are provided to change the direction of feed as required by the individual using unit for their particular vehicle application.

Table 2-2. Equipment Conversion—Feed Direction

step	Action	Reference
1.	Remove cover assembly.	Paragraph 2-11 for disassembly / assembly and figure 2-1 for right and left hand feed.
<b>COVER ASSEMBLY</b>		
2.	Slide feed support retainer to enable removal of feed cam.	
3.	Remove feed cam.	
4.	Remove feed support assembly.	
5.	Remove feed slide track assembly and feed slide, reverse 180° and install.	
6.	Install feed support assembly.	
7.	Reposition and install feed cam (position feed support retainer).	
<b>FEED TRAY GROUP</b>		
8.	Remove feed tray group.	
9.	Remove cartridge stop assembly, turn 180° and install on left side of feed tray group.	
<b>NOTE</b>		
For right-hand feed, cartridge stop assembly is positioned to left side of feed tray group when feed tray group is installed in receiver assembly.		
10.	Install feed tray group.	
11.	Install cover assembly.	

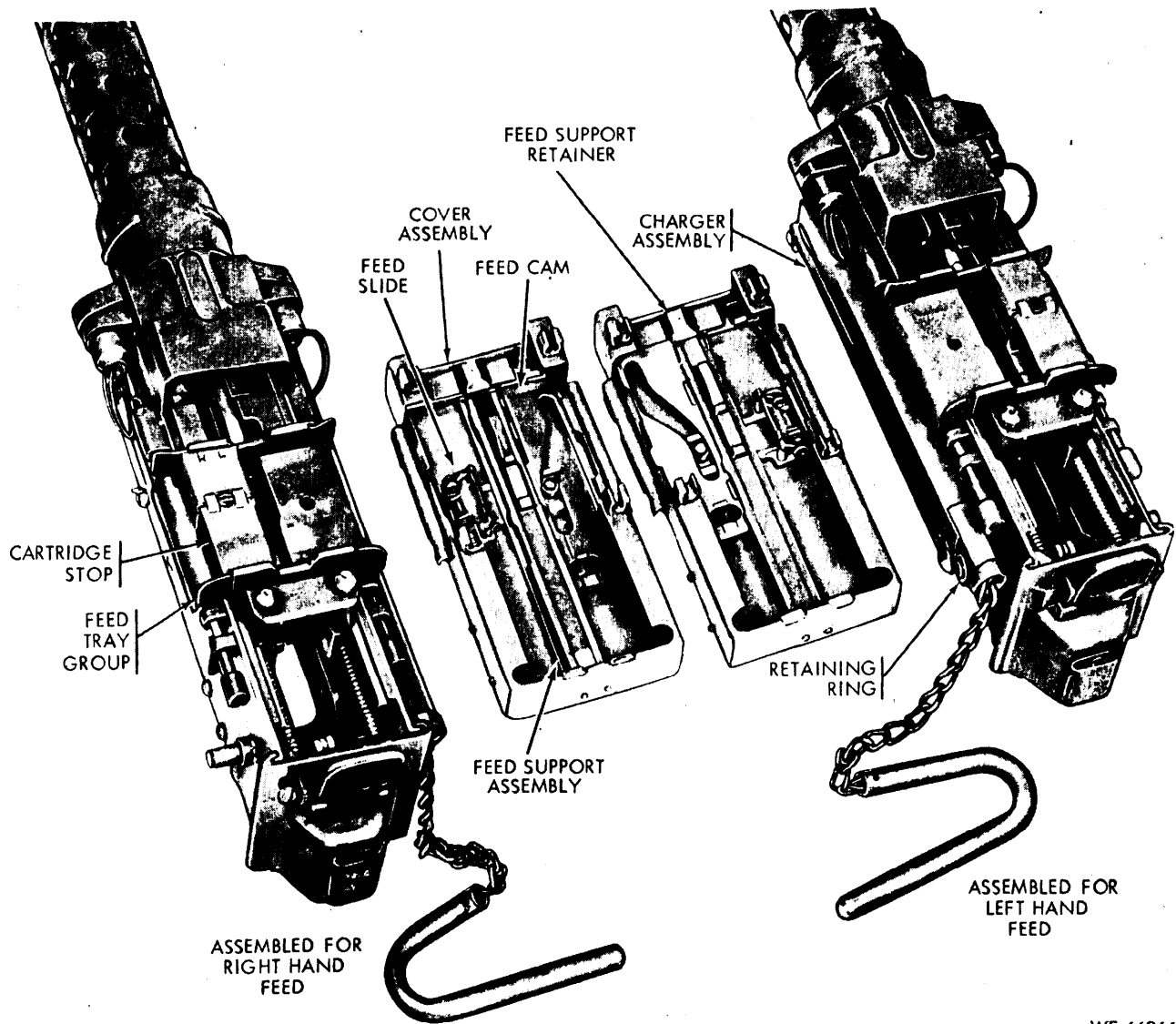

WE 66366

Figure 2-1. 7.62-MM Machine Gun M 73 assembled for right and left hand feed.

b. *Repositioning of Charger Assembly.* Normally the charger assembly will be positioned on the left side of the machine gun. However, some vehicle applications utilize the charging assembly on the

right side of the weapon. The following conversion instructions in table 2-3 are provided to change the charger assembly as required by the individual using unit for their particular vehicle application.

Table 2-3. Equipment Conversion—Charger Assembly

Step	Action	Reference
1.	Remove retaining ring.	Paragraph 2-11 for disassembly / assembly.
2.	Remove charger assembly.	
3.	Depress connector slide retainer.	
4.	Reposition charger slide retainer—from left hand to right hand.	
5.	Remove retaining ring, reposition buffer pivot pin from left-hand to right-hand, and reposition retaining ring.	
6.	Reposition charger mounting stud from left-hand side to right-hand side of receiver assembly (M73A1 and M219 only).	
7.	Install charger assembly on right-hand side of weapon.	
8.	Install retaining ring on right-hand side of weapon.	

**Section II. REPAIR PARTS, SPECIAL TOOLS, AND EQUIPMENT**

**2-3. General**

a. Repair parts, special tools, test, and support equipment are listed in appendix C.

b. Maintenance supplies and materials used for cleaning, lubricating, and preserving the machine gun are listed in table 2-4 with their Federal stock numbers. Pertinent authorization documents are the proper requisitioning authority for these

maintenance expendable supplies and materials. The maintenance level column indicates the lowest category of maintenance authorized to utilize the particular item. The maintenance level codes used are:

<i>Code</i>	<i>Explanation</i>
C	Operator / crew
0	Organizational maintenance

*Table 2-4. Maintenance Supplies and Materials*

FSN	Description	Maintenance level
8020-244-0153	BRUSH, ARTISTS: metal, ferrule, flat, chisel edges, 7 / 16 w, 1-1 / 8 lg, exposed bristle	C
7920-205-2401	BRUSH, CLEANING, TOOL AND PARTS: rd, 100 percent tampico fiber, 1-1 / 6 at ferrule brush dia, 2-7/ 8 clear of block brush lg	C
6850-965-2332	CARBON REMOVING COMPOUND: (5 gal pail) P-C-IIIb.	0
6850-224-6657	CLEANING COMPOUND, RIFLE BORE: (RBC)	C
6850-224-6663	8 oz can	
5350-221-0872	1 gal can	
6850-281-1985	CLOTH, ABRASIVE: crocus, ferric oxide and quartz, jean-cloth-backing, closed coating, 9 w, 11 lg, 50 sh-sleeve (CA)	C
9150-273-2389	DRY CLEANING SOLVENT: (SD) (1 gal can)	C
9150-231-6689	LUBRICATING OIL, GENERAL PURPOSE: (PL special)	C
9150-889-3522	4 oz can	
(See section VI, appendix C.)	1 qt can	
9150-292-9689	LUBRICATING OIL, SEMI-FLUID: (LSA) (4 oz flat oval bottle)	C
7920-205-1711	LUBRICATING OIL, WEAPONS: (LAW) for below zero operations (1 qt can)	C
	RAG, WIPING: cotton, for general purpose use (50 lb bale)	C

**Section III. LUBRICATION INSTRUCTIONS**

**2-4. General**

Depending on the weather and areas to be lubricated, there are three lubricants which can be used.

a. *PL Special (General Purpose Lubricating Oil)*. Use PL special for general use on all parts of the weapon other than those specified in paragraph 2-5b (1 thru (3), below. when temperature is expected to vary down to —30° F temporarily.

b. *LAW (Weapons Lubricating Oil)*. Use LAW for all parts of the weapon other than those specified in paragraph 2-5b (1) thru (3), below, when temperature is expected to remain from 0° to minus 65°F.

c. *LSA (Semifluid Lubricating Oil)*. Use LSA for specific areas in accordance with paragraph 2-5b below. LSA can be used on these areas at all temperature ranges.

**2-5. Lubrication Under Usual Conditions**

a. Disassemble the machine gun into its major groups and assemblies, clean (para 2-12a), wipe dry, and oil with PL special (general purpose lubricating oil) for above 0° operation.

**CAUTION**

**DO NOT use rifle bore cleaning compound (or any liquids) to clean the back plate assembly. Use clean cloths to remove foreign matter. DO NOT lubricate the back plate assembly for danger of contamination of the solenoid.**

b. LSA should be used on certain critical areas listed below. Apply LSA sparingly by squeezing a small amount of lubricant from the plastic bottle. After lubricating, the components should be cycled by hand, as in functioning, to allow the oil to spread. LSA will be applied to the following areas:

(1) *Cover assembly.* In recesses or grooves where the belt feed slide and the feed cam rides.

(2) *Barrel extension assembly.* In receiver rail and cartridge rammer grooves, and on all rollers and roller riding surfaces.

(3) *Receiver assembly.* On all rails and camming grooves.

NOTE

Never apply LSA to the rate control slide components.

c. After lubricating assemble the weapon.

NOTE

Remove oil from bore before firing.

d. During periods of inactivity, clean and oil as above every 90 days unless inspections reveal shorter intervals are required.

## 2-6. Lubrication Under Unusual Conditions

a. *General.* Special care is necessary whenever extremes in weather either exist or are expected. Proper care of weapon not only insures proper functioning, but also guards against wear and deterioration.

b. *Operation in Extreme Cold.*

NOTE

Lubricate machine gun and mount with LAW instead of PL special when temperature is expected to remain below zero. PL special can be used when temperature is expected to vary down to  $-30^{\circ}$  F., temporarily. Regardless of temperature, LSA should be used on components and areas listed in paragraph 2-5b.

(1) Keep all moving parts free from moisture.

(2) Do not oil parts excessively. Excess oil solidifies and causes sluggish operation or complete failure.

(3) Hand operate machine gun frequently during periods of low temperature (below  $0^{\circ}$  F.) to insure proper functioning.

(4) Before firing in temperature below  $0^{\circ}$ F, completely disassemble and clean all parts of the machine gun thoroughly and lubricate.

(5) After firing the machine gun, clean (para 2-12a) and lubricate with LAW and LSA (para 2-4 and 2-5).

(6) Cover all equipment, kept outside.

(7) When machine gun is brought indoors, moisture is likely to condense on the cold surfaces. First allow equipment to reach room temperature, disassemble, wipe off all moisture, lubricate, and assemble.

c. *Lubrication in Hot, Dry, Humid, and Salty Climates.*

(1) High temperatures and humidity tend to dissipate and contaminate lubricants. Therefore, *more frequent* servicing is necessary than for usual conditions. Inspect daily or more frequently if necessary and clean (para 2-12a) as necessary.

(2) Make certain that unexposed parts as well as exposed surfaces are kept free of moisture, clean and oiled.

(3) After inspection and cleaning, lubricate with PL special and LSA (para 2-4 and 2-5).

d. *Lubrication in Dusty and Sandy Areas.*

(1) Inspect daily and clean (para 2-12a) as necessary.

(2) Wipe lubricants from exposed and non-critical operating surfaces. This prevents sand from sticking to the lubricant and forming an abrasive which can damage the machine gun.

(3) As soon as possible after use in sandy terrain clean equipment and lubricate (para 2-4 and 2-5). Then wipe dry as directed in (2) above.

(4) After handling, wipe machine gun with a dry rag to remove perspiration to prevent rust.

(5) Cover equipment as much as possible when operating in dusty or sandy areas.

e. *Lubrication After Exposure to Water.*

(1) When splashed or submerged, water will seep into the inner parts of the equipment and can cause rust to form.

(2) If splashed or submerged, disassemble completely, clean (para 2-12a), lubricate, and assemble.

## Section IV. PREVENTIVE MAINTENANCE CHECKS AND SERVICES

### 2-7. General

Refer to table 2-5.

Table 2-5. Organizational Preventive Maintenance Checks and Services

Q-Quarterly

Total man- hours required: .5 hrs

Sequence Number	Item to be Inspected Procedure	Work Time (M / H)
1	<p style="text-align: center;"><b>WARNING</b></p> <p><b>Before starting an inspection, be sure to clear the weapon. Do not actuate the trigger until the weapon has been cleared. Inspect the chamber to insure that it is empty and check to see that no ammunition is in position to be introduced.</b></p> <p style="text-align: center;"><b>MACHINE GUN</b> Man-hours required:</p> <p>General Condition</p> <p>Inspect protective coatings for effectiveness. Check for missing, loose, or damaged parts, tools, or equipment. Check to insure compliance with cleaning and lubricating instructions — (refer to paragraphs 2-4, 2-5, 2-6, 2-12a and pertinent vehicle operator’s manual). Inspect cover latch rod assemblies (22, figs C-12 and C-13) for proper function. Check functioning with dummy cartridge. Make certain safety positively prevents firing when in S (safe) position. Assure that electrical connectors are intact and that solenoid functions properly.</p>	.5

**Section V. TROUBLESHOOTING**

**2-8. General**

a. *General.* Refer to paragraphs b thru f, below, for general data on malfunctions and corrective action to be taken. For specific troubleshooting procedures, refer to table 2-6.

b. *Runaway Gun.*

**CAUTION**

**Hold fire on target until feeding of ammunition is stopped.**

(1) Pull and hold charging handle to the rear to stop firing.

(2) Unload the gun as follows:

(a) Place safety in safe “S” position.

(b) open cover (ammunition link belt will drop out).

(c) Examine chamber to make certain it is clear.

(3) Locate and correct cause (table 2-6).

c. *Ruptured Cartridge Case, Live Round, or Empty Case.*

(1) *General.* In most cases of complete rupture of a cartridge case, the forward portion of the case remains in the chamber and extraction is accomplished only on the rear portion. When a rupture of this type occurs a new round will be fed into the chamber. This new round cannot be seated fully. It may be compressed sufficiently to cause

deterioration with possible damage to the weapon, injury to personnel, or both. If the new round driven into the ruptured case does not detonate, remove the round and the ruptured case as specified in (2) below. Refer to (3) below for removal of live round or empty case.

(2) *Removal of ruptured cartridge case (fig 2-2).*

(a) Place ruptured cartridge case extractor in breech end of barrel.

(b) Place the cleaning rod into the muzzle end of the barrel and tap the rod gently to remove the cartridge.

(c) If the ruptured cartridge case remains in the chamber, insert the ruptured cartridge case extractor through the case. Insert cleaning rod into muzzle end of barrel and tap the rod lightly to remove case.

(d) Clean chamber.

(3) *Removal of live round or empty case (fig 2-2).*

(a) Retract barrel extension to move breech block. Hold in retracted position.

(b) Using combination tool, place extractor end in groove of cartridge case and pry forward to remove live round or empty case.

(c) Clean chamber.

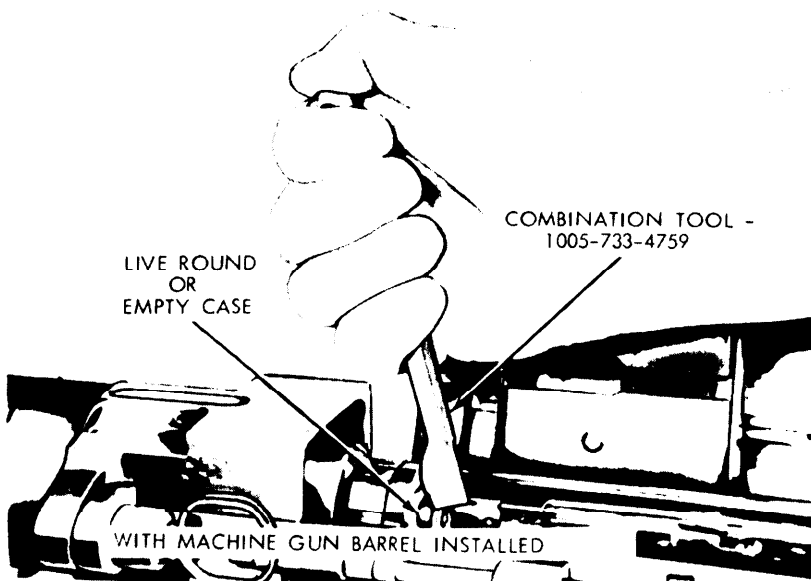
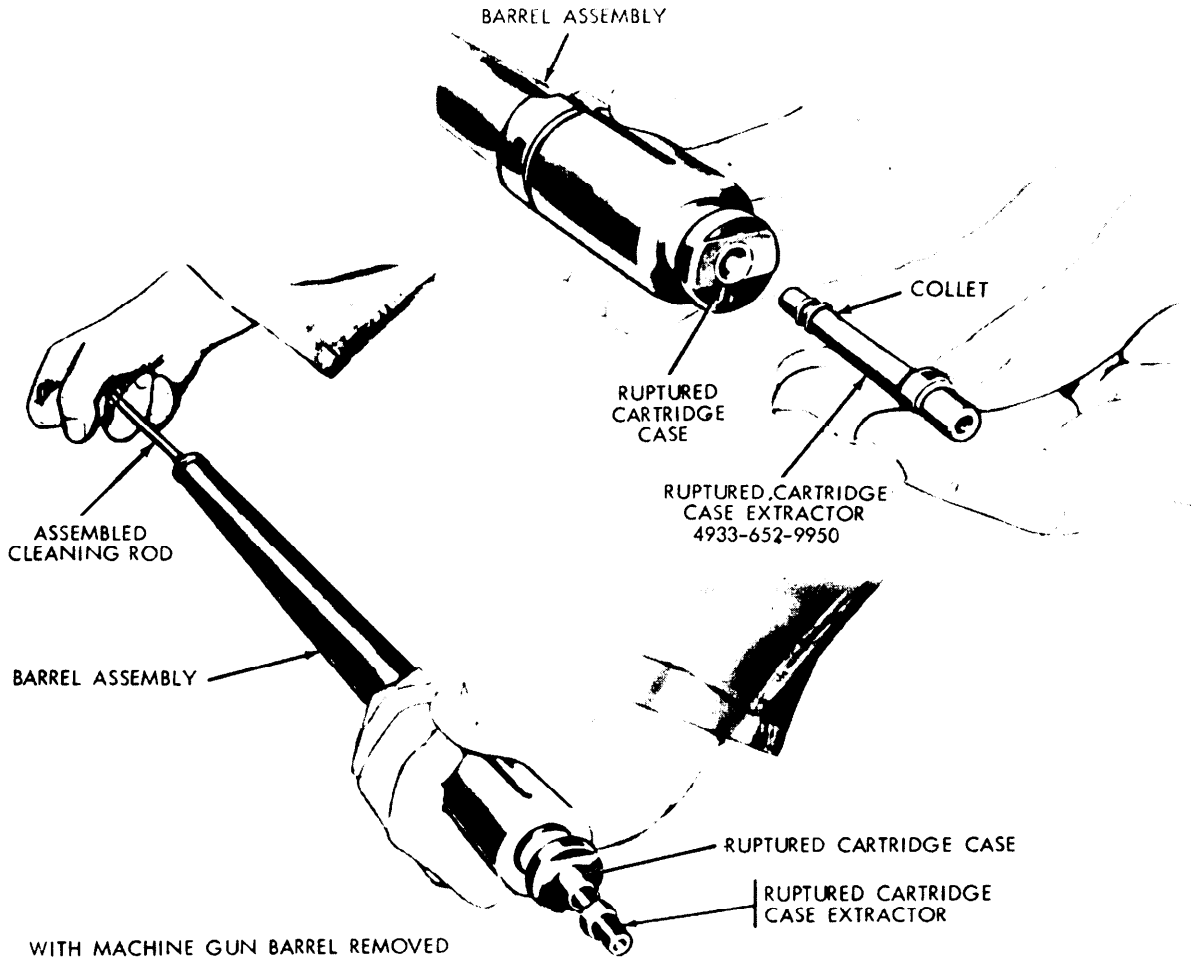

WE 68855

Figure 2-2. Removal of ruptured cartridge case, live round, or empty case.

d. *Misfire, Hangfire, Cook-off and Stoppage.*

**WARNING**

**In the event of a misfire the round will remain locked in the chamber for the prescribed time intervals, the gun trained on the target, and personnel cleared from the area.**

(1) *Misfire.* A misfire is the failure of a chambered round to ignite when the firing mechanism is actuated. Such failure can be due to an ammunition defect or faulty firing mechanism in the weapon. A misfire in itself is not dangerous, but because it cannot be immediately distinguished from a hangfire it should be handled as described below.

(2) *Hangfire.* A hangfire is a delay in the igniting of the propellant charge after the primer has been struck by the firing pin. It is not easily distinguished from a misfire. Time intervals prescribed in paragraph e, below, must be observed before opening the chamber after a failure to fire.

(3) *Cook-off.* A cook-off is the igniting of a round, due to the heat of a very hot barrel, rather than the actuating of the firing mechanism. Observe the same precautions as for a hangfire. A cook-off may be avoided by immediately firing ammunition loaded in a hot gun or by unloading the weapon in the time specified in paragraph e, below.

(4) *Stoppage.* A stoppage is any interruption in the cycle of operation of a machine gun caused by faulty action of the gun or ammunition.

e. *Immediate Action Procedures for Removing a Live Round in Case of Failure to Fire.*

(1) *Cool weapon.* When a stoppage occurs (failure to fire) before completing a 200 round series, starting from a cool machine gun, perform the operations listed below.

(a) Wait five seconds in the event of a hangfire.

**WARNING**

**Keep weapon trained on target.**

(b) Charge weapon, if possible, to sear position and attempt to fire.

(c) If the weapon fails to fire, charge weapon again and place safety in safe "S" position.

(d) Open cover assembly and remove belted ammunition.

(e) Remove live ammunition or spent cartridges and links from weapon chamber and / or immediate area.

(f) Slide safety into fire "F" position and hand-function weapon one cycle.

(g) Load weapon and attempt to fire.

(h) If the weapon still fails to function, inspect cause of stoppage. Refer to troubleshooting, table 2-6.

(2) *Hot weapon.* When a stoppage occurs (failure to fire), after a burst of approximately 200 rounds fired either spasmodically or continuously within two minutes, perform the operations listed below.

(a) **DO NOT OPEN COVER ASSEMBLY.**

**WARNING**

**The danger of an open-cover cook-off exists when the weapon is hot. Immediate action must be applied within ten seconds. Under no circumstances will the cover be opened during this period.**

(b) Wait five seconds in the event of a hangfire.

(c) Immediately attempt to charge weapon, keeping cover closed and attempt to fire weapon.

(d) If firing cannot be resumed, charge the weapon to sear position and slide safety to safe "S" position.

**WARNING**

**Allow the weapon to cool at least five minutes before attempting to open cover assembly.**

(e) Open cover, clear, and inspect weapon for cause of stoppage. Refer to troubleshooting, table 2-6.

f. *Double Feed.*

(1) *General.* A double feed, with subsequent possibility of damage to the gun and injury to personnel, will occur whenever a round is fed into a chambered spent case or live round.

(2) *Double feed into "spent" case.* When the gun fails to extract the "spent" case, the barrel extension assembly automatically will recoil, strip the next round from the belt, and feed it into the chambered case. The force may compress the round sufficiently to cause detonation, and cause damage to the gun and injury to personnel.

(3) *Double feed into live round.* When a round does not fire, the barrel extension assembly remains in the forward or closed position. This causes a stoppage, which must be treated as a hangfire, d (2) above. When the gun is charged, and the round fails to extract and the trigger is pulled, the next round could strike the primer of the first round causing it to fire.

**WARNING**

**Do not retract the charger handle and allow it to go forward if belted ammunition is on the feed tray and a "live" round is in the chamber.**



Table 2-6. Organizational Troubleshooting

Malfunction	Probable Cause	Corrective Action
<p>1. Failure to feed</p> <p>2. Failure to chamber</p> <p>3. Failure to lock</p>	<p>a. Defective link or ammunition.</p> <p>b. Cover unlatched.</p> <p>c. Loading with barrel extension assembly in the forward position, round in feed tray slot and cover c load.</p> <p>d. Defective retaining pawls (belt holding).</p> <p>e. Defective retaining pawl springs.</p> <p>f. Defective feed pawl.</p> <p>g. Defective feed pawl spring.</p> <p>h. Defective feed cam.</p> <p>i. Defective feed slide track.</p> <p>j. Defective feed slide assembly.</p> <p>k. Missing feed slide roller and retaining ring.</p> <p>l. Defective cover latch rod.</p> <p>m. Defective cover latch assemblies.</p> <p>n. Defective driving stud.</p> <p>a. Defective ammunition (short round).</p> <p>b. Ammunition belt installed upside down.</p> <p>c. Defective driving springs.</p> <p>d. Obstruction (foreign substance or material in chamber).</p> <p>e. Defective cartridge depressor.</p> <p>f. Defective cartridge rammer (M73 only) or rammer and extractor assembly M73A1 and M219.</p> <p>g. Defective cartridge stripper.</p> <p>h. Defective cartridge depressor spring.</p> <p>i. Defective cartridge stripper spring.</p> <p>j. Defective rammer actuator roller.</p> <p>k. Defective feed slide track assembly.</p> <p>l. Defective feed tray.</p> <p>a. Defective firing pin extension.</p> <p>b. Defective driving springs.</p> <p>c. Defective barrel extension.</p>	<p style="text-align: center;">NOTE</p> <p>For malfunctions encountered but not listed, or if corrective action does not remedy condition, notify direct support maintenance.</p> <p>a. Remove faulty link and /or round.</p> <p>b. Clew cover.</p> <p>c. Load properly.</p> <p>d. Replace slide track assembly.</p> <p>e. Replace slide track assembly.</p> <p>f. Evacuate to direct support maintenance.</p> <p>g. Evacuate to direct support maintenance.</p> <p>h. Evacuate to direct support maintenance.</p> <p>i. Evacuate to direct support maintenance.</p> <p>j. Evacuate to direct support maintenance.</p> <p>k. Evacuate to direct support maintenance.</p> <p>l. Evacuate to direct support maintenance.</p> <p>m. Evacuate to direct support maintenance.</p> <p>n. Evacuate to direct support maintenance.</p> <p>a. Remove faulty round.</p> <p>b. Install belt properly (open sides of links facing downward).</p> <p>c. Replace.</p> <p>d. Remove obstruction.</p> <p>e. Evacuate to direct support maintenance.</p> <p>f. Replace barrel extension assembly.</p> <p>g. Evacuate to direct support maintenance.</p> <p>h. Evacuate to direct support maintenance.</p> <p>i. Evacuate to direct support maintenance.</p> <p>j. Replace barrel extension assembly.</p> <p>k. Replace.</p> <p>l. Replace.</p> <p>a. Replace barrel extension assembly.</p> <p>b. Replace.</p> <p>c. Replace.</p>

Table 2-6. Organizational Troubleshooting—Continued

Malfunction	Probable Cause	Corrective Action
3. Failure to lock (cont.)	<ul style="list-style-type: none"> <li>d. Defective breechblock roller.</li> <li>e. Defective breechblock roller shaft.</li> <li>f. Defective or missing breech block cam.</li> <li>g. Defective breechblock cam plunger spring.</li> <li>h. Defective lever actuator roller.</li> </ul>	<ul style="list-style-type: none"> <li>d. Replace barrel extension assembly.</li> <li>e. Replace barrel extension assembly.</li> <li>f. Evacuate to direct support maintenance.</li> <li>g. Evacuate to direct support maintenance.</li> <li>h. Replace barrel extension assembly.</li> </ul>
4. Failure to fire	<ul style="list-style-type: none"> <li>a. Defective barrel extension.</li> <li>b. Defective firing pin.</li> <li>c. Defective firing pin extension.</li> <li>d. Defective ammunition.</li> <li>e. Defective firing circuit.</li> <li>f. Defective hammer spring.</li> <li>g. Defective or missing rate control pawl.</li> <li>h. Defective or missing rate control pawl spring.</li> <li>i. Defective hammer sear.</li> <li>j. Faulty solenoid adjustment.</li> <li>k. Defective solenoid.</li> <li>l. Defective rate control slide.</li> <li>m. Defective rate control slide spring.</li> <li>n. Faulty sear adjustment.</li> </ul>	<ul style="list-style-type: none"> <li>a. Replace.</li> <li>b. Replace barrel extension assembly.</li> <li>c. Replace breechblock assembly.</li> <li>d. Replace.</li> <li>e. Check firing circuit.</li> <li>f. Replace barrel extension assembly.</li> <li>g. Replace barrel extension assembly.</li> <li>h. Replace barrel extension assembly.</li> <li>i. Replace barrel extension assembly.</li> <li>j. Evacuate to direct support maintenance.</li> <li>k. Evacuate to direct support maintenance.</li> <li>l. Evacuate to direct support maintenance.</li> <li>m. Evacuate to direct support maintenance.</li> <li>n. Adjust properly (pars 4-3).</li> </ul>
5. Failure to unlock	<ul style="list-style-type: none"> <li>a. Defective lever actuator roller.</li> <li>b. Defective barrel jacket.</li> <li>c. Loose barrel bearing.</li> </ul>	<ul style="list-style-type: none"> <li>a. Replace barrel extension assembly.</li> <li>b. Evacuate to direct support maintenance.</li> <li>c. Reposition lock, tighten bearing and stake.</li> </ul>
6. Failure to extract	<ul style="list-style-type: none"> <li>a. Defective cartridge case (rupture).</li> <li>b. Defective extractor (M73 only) or rammer and extractor assembly M73A1 and M219 only).</li> <li>c. Defective cartridge rammer (M73 only).</li> <li>d. Defective extractor spring (M73 only).</li> <li>e. Pitted chamber.</li> <li>f. Short recoil.</li> </ul>	<ul style="list-style-type: none"> <li>a. Immediately replace barrel; remove ruptured case when tactical situation permits.</li> <li>b. Replace barrel extension assembly.</li> <li>c. Replace barrel extension assembly.</li> <li>d. Replace barrel extension assembly.</li> <li>e. Inspect. Replace barrel assembly, if necessary.</li> <li>f. Investigate for binding parts. Clean and lubricate as required.</li> </ul>
7. Failure to eject	<ul style="list-style-type: none"> <li>a. Defective extractor (wings) (M73 only).</li> <li>b. Defective case carrier body (projections) (M73 only).</li> <li>c. Defective case carrier grips (M73 only).</li> <li>d. Defective case carrier grip inner and outer springs (M73 only).</li> <li>e. Round case grips assembled incorrectly (M73 only).</li> </ul>	<ul style="list-style-type: none"> <li>a. Replace barrel extension assembly.</li> <li>b. Replace barrel extension assembly.</li> <li>c. Replace barrel extension assembly.</li> <li>d. Replace barrel extension assembly.</li> <li>e. Replace barrel extension assembly.</li> </ul>

Table 2-6. *organizational Troubleshooting—Continued*

Malfunction	Probable Cause	Corrective Action
7. Failure to eject (cont)	f. Defective case carrier link assembly (M73 only). g. Defective feed tray (M73A1 and M219 only).	f. Replace barrel extension assembly. g. Replace.
8. Failure to cock	a. Defective hammer sear. b. Defective hammer. c. Defective hammer cocking roller. d. Defective hammer sear spring.	a. Replace barrel extension assembly. b. Replace barrel extension assembly. c. Replace barrel extension assembly. d. Replace barrel extension assembly.
9. Uncontrolled fire	e. Defective barrel extension. a. Defective barrel extension (sear notches). b. Defective trigger sear (hooks). c. Defective solenoid.	e. Replace. a. Replace. b. Evacuate to direct support maintenance. c. Evacuate to direct support maintenance.
10. Erractic firing rate	Loose rate control guide screw (15, fig C-12 and C-13) and rate control guide support screw (16, figs C-12 and C-13). Missing rate control pawl.	Tighten screws and restake.
11. Improper rate control		Replace barrel extension assembly.
12. Excessive rearward movement (recoiling parts)	a. Buffer assembly (early design) installed upside down (M73 only). b. Defective buffer support spring. c. Faulty buffer adjustment.	a. Install buffer assembly properly. b. Replace. c. Evacuate to direct support maintenance.
13. Failure to load	a. Feed components assembled incorrectly (cover assembly). b. Defective cover latch rod spring. c. Defective cover latch rod.	a. Assembly correctly (fig C-3). b. Evacuate to direct support maintenance. c. Evacuate to direct support maintenance.

**Section VI. ORGANIZATIONAL MAINTENANCE PROCEDURES**

**2-9. General**

Inspect components for rust, corrosion, burrs, scored areas or foreign matter and remove. Inspect springs for deformation and replace if necessary. Inspect for damaged threads of screws and other components. Inspect for appearance proper assembly and functioning. Repair or replace un-serviceable parts as authorized.

**NOTE**

Maintenance of some groups and assemblies are not authorized by the maintenance allocation chart (app B) to organizational maintenance.

Insure that no work is being accomplished beyond the scope authorized to organizational maintenance. Evacuate to direct and general support maintenance for repairs when necessary.

**2-10. Removal / Installation**

*a. Removal / Installation of Machine Guns.* Detailed instructions on removal and / or installation of the machine guns in the appropriate vehicles are found in the pertinent vehicle operators technical manual.

*b. Removal / Installation of Flash Hider.* Refer to figure 2-3.

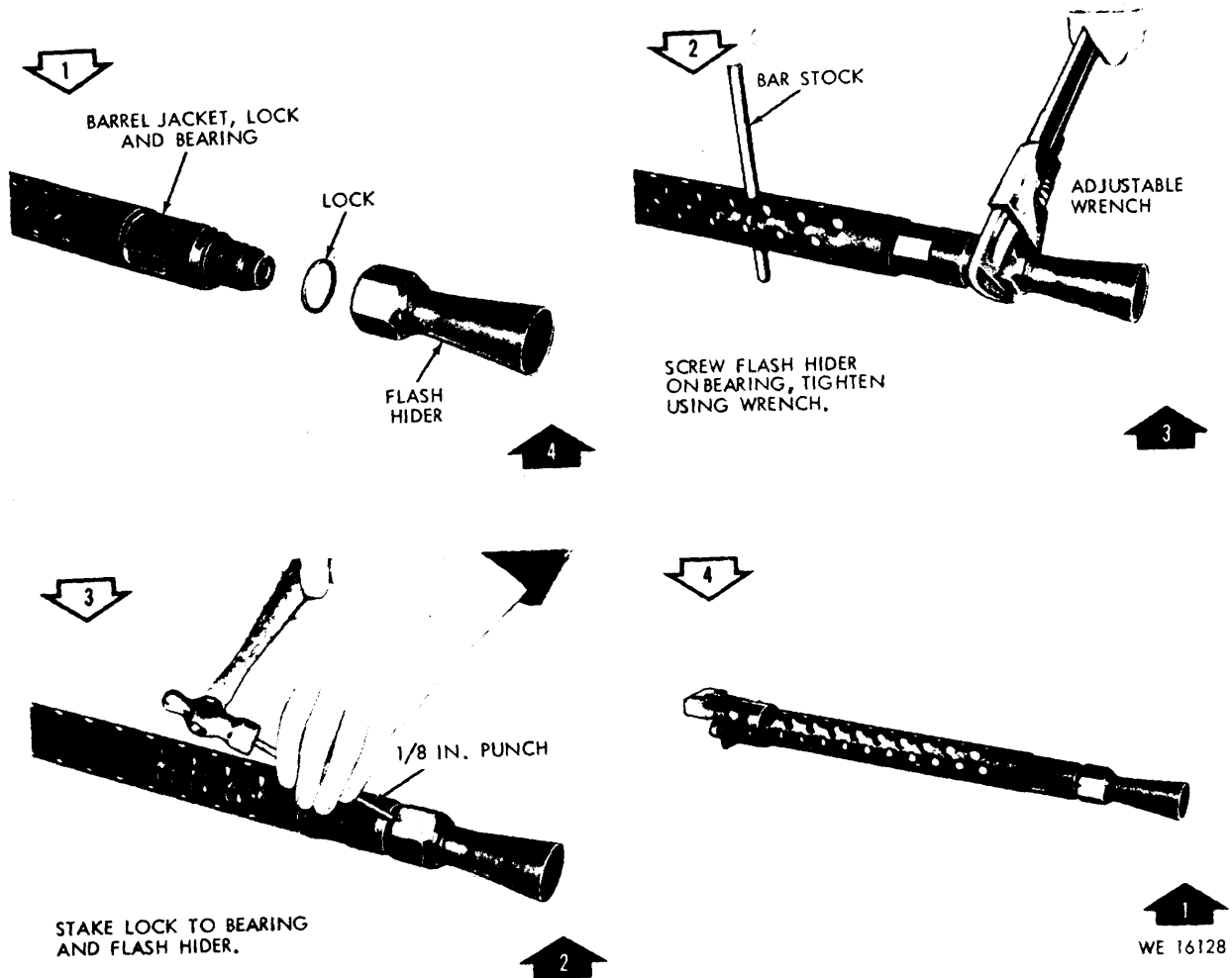

Figure 2-3. Removal/installation of flash hider.

**2-11. Disassembly / Assembly**

a. *General.* White arrows in figures 2-4 thru 2-10 indicate disassembly sequence, and black arrows indicate assembly sequence.

b. *Machine Gun.* Refer to table 2-7 for disassembly / assembly procedures. In the

sequence in table 2-7 all parts are installed for left-hand feed. While the M73 is not actually shown in figures 2-4 thru 2-7, the procedures are the same.

c. *Cover Assembly.* Refer to figures 2-8 and 2-9.

d. *Receiver Assembly.* Refer to figure 2-10.

Table 2-7. Disassembly-Assembly of Machine Guns

Disassembly step	Assembly step	Procedure	Reference
(White Arrows)	(Black Arrows)	<p style="text-align: center;"><b>WARNING</b></p> <p><b>Before starting, be sure to clear the weapon. DO NOT actuate the trigger until the weapon has been cleared. Inspect the chamber to insure that is it empty, and check to see that no ammunition is in position to be introduced.</b></p>	
1	13	<p>Barrel extension assembly is in rear position (charged), place trigger safety in the fire "F" position. Pull charger handle rearward and, while keeping tension on handle, depress manual firing trigger, allowing barrel extension to go forward slowly. Charge the machine gun, then place safety in safe "S" position. Depress the manual firing trigger. The barrel extension assembly should not release.</p> <p><i>FUNCTIONAL CHECK.</i> Check the functioning several times by pulling charger to rear, and while maintaining tension on handle, depress the manual firing trigger. Barrel extension must release with safety in fire "F" position.</p>	Fig 2-4
2	12	<p>Pull either disconnecter pull ring, rearward, rotate jacket assembly with bearing group until mounting block is free of receiver assembly. Remove jacket assembly from receiver.</p> <p style="text-align: center;"><b>NOTE</b></p> <p>When installing, position jacket assembly mounting block hole on one disconnecter pull ring, pull out on opposite disconnecter pull ring, rotate the group into position, and release ring.</p>	Fig 2-5
3	11	<p>To remove, pull barrel assembly from jacket assembly. When installing, position barrel assembly into rear of jacket assembly until the slot in barrel is alined with barrel locator. Push barrel forward until stopped by locator.</p>	Fig 2-5
4-5	9-10	<p style="text-align: center;"><b>CAUTION</b></p> <p><b>Turn barrel assembly to make certain barrel locator enters barrel slot.</b></p> <p>Remove cover assembly from receiver assembly. When installing, position cover assembly on cover latch rod assemblies, then press down on cover until it locks in position.</p> <p style="text-align: center;"><b>NOTE</b></p> <p>Cover latch rod assemblies in locked (forward) position. Locks are released automatically by cover assembly when installed.</p>	Fig 2-6
6	8	<p>Lift and remove feed tray group. When installing, position feed tray group with cartridge stop on the right of the receiver. The feed tray group may be removed or installed with cover assembly.</p>	Fig 2-6
7	7	<p style="text-align: center;"><b>WARNING</b></p> <p><b>Make certain that the barrel extension assembly is in forward position to prevent injury to personnel.</b></p> <p>Push guide rod assemblies forward, rotate ¼ turn counter-clockwise to unlock, then remove rod assemblies and helical compression (driving) springs from holes in the back plate assembly with solenoid. To install, position springs on guide rods, insert in holes in back plate, and into holes in rear of barrel extension, compress and rotate clockwise until secure.</p>	Fig 2-6
8	6	<p>Slide back plate assembly with solenoid upward and remove from receiver assembly. To install aline grooves on back plate with flanges on receiver assembly and lower to receiver tabs.</p>	Fig 2-6
9	5	<p style="text-align: center;"><b>CAUTION</b></p> <p><b>Slamming of the back plate during installation will lower the receiver tabs and can create a "runaway" gun.</b></p> <p>Pull rearward on charger handle of charger assembly until barrel extension group is fully retracted.</p>	Fig 2-6

Table 2-7. Disassembly/ Assembly of Machine Guns—Continued

Disassembly step	Assembly step	Procedure	Reference
		<p><b>WARNING</b></p> <p><b>Use the hand charger assembly handle to retract barrel extension assembly. Never use the hands.</b></p>	
		<p><b>NOTE</b></p> <p>Depress right or left-hand buffer support lever to release and/or install the barrel extension group.</p>	
10	4	<p>Grasp top portion of barrel extension assembly, depress buffer support lever then pull rearward and slide barrel extension group from receiver assembly. To assemble, align barrel extension assembly camway with barrel extension rail on receiver, depress buffer support lever, then push barrel extension fully forward. The breechblock must be flush with the right side of the barrel extension assembly and engage the rail of the receiver.</p>	Fig 2-7
11	3	<p>Slide top portion of breechblock assembly left to center of barrel extension channel in barrel extension assembly, then lift straight up to remove. To install, position top portion of breechblock assembly in center of barrel extension channel, lower to align with breechblock camways, then slide breechblock to right.</p>	Fig 2-7
		<p><b>NOTE</b></p> <p>Right top edge of breechblock assembly must align (flush ) with right top edge of barrel extension assembly when installing in the machine gun.</p>	
12	2	<p>Remove retaining ring from charger mounting stud on receiver assembly that secures the charger assembly to receiver assembly.</p>	Fig 2-7
13	1	<p>Pull hand charger off charger mounting stud and disengage front end of charger from buffer pivot pin on receiver assembly. To install, position the forward end of charger on pivot pin, slide in position on charger mounting stud, then secure charger to stud with retaining ring.</p>	Fig 2-7

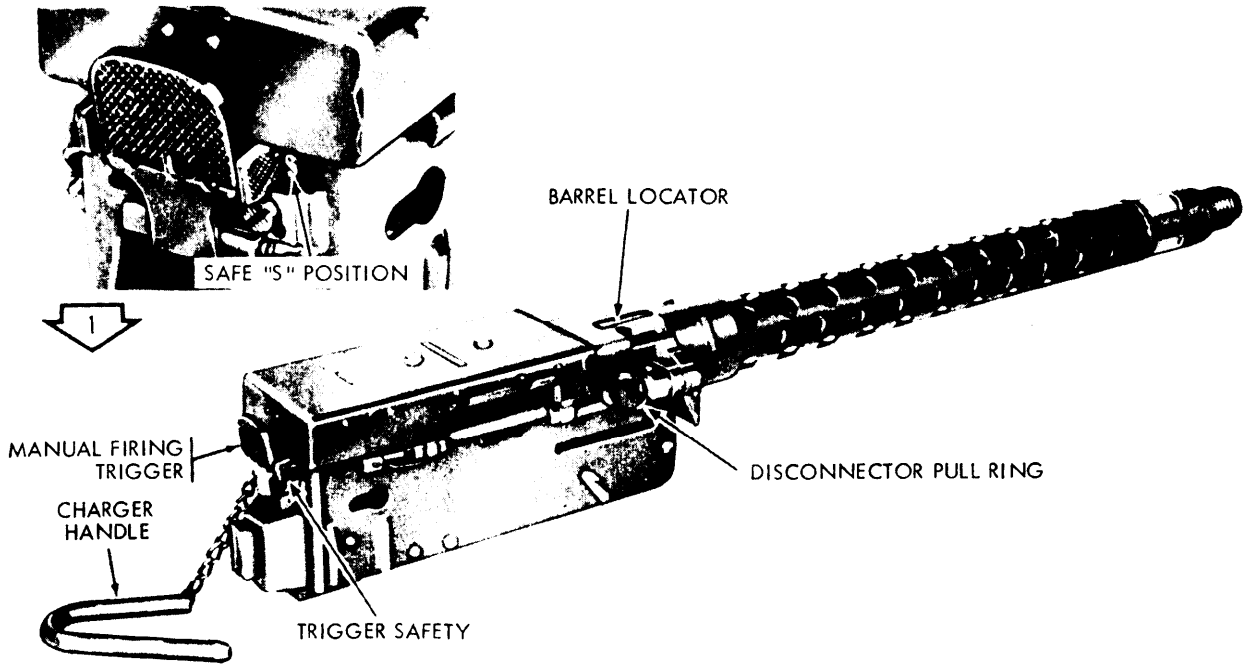

7.62-MM MACHINE GUN M73A1/M219 - REMOVED FROM VEHICLE - RIGHT REAR VIEW.

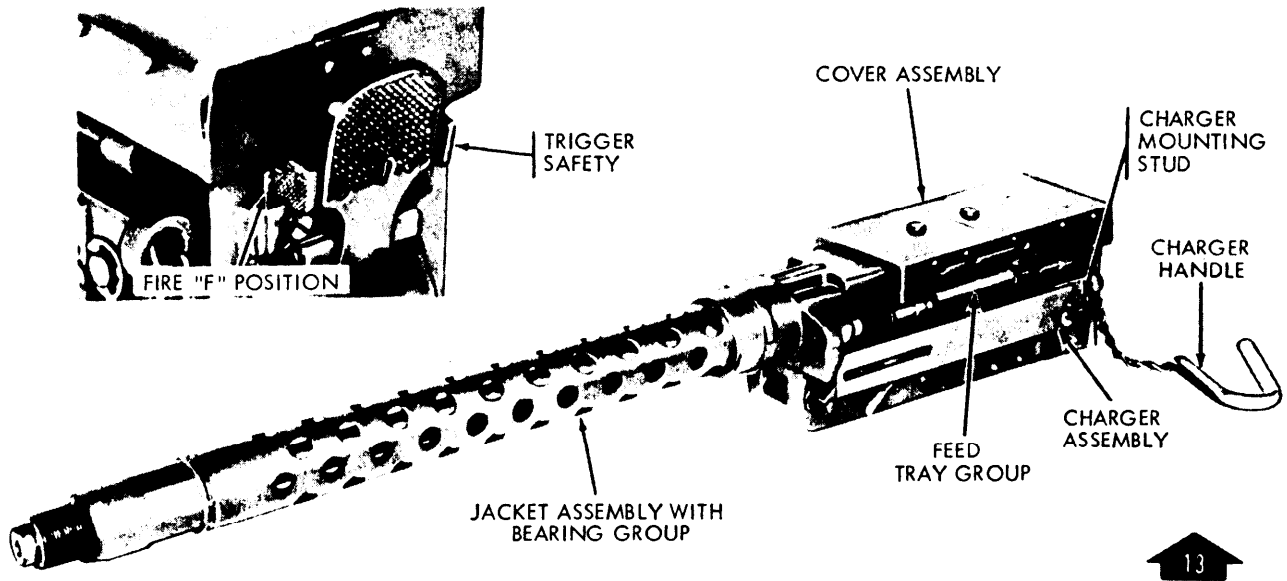

7.62-MM MACHINE GUN M73A1/M219 - REMOVED FROM VEHICLE - LEFT FRONT VIEW.

WE 66367

Figure 2-4. Disassembly/ assembly of machine gun. (1 of 4)

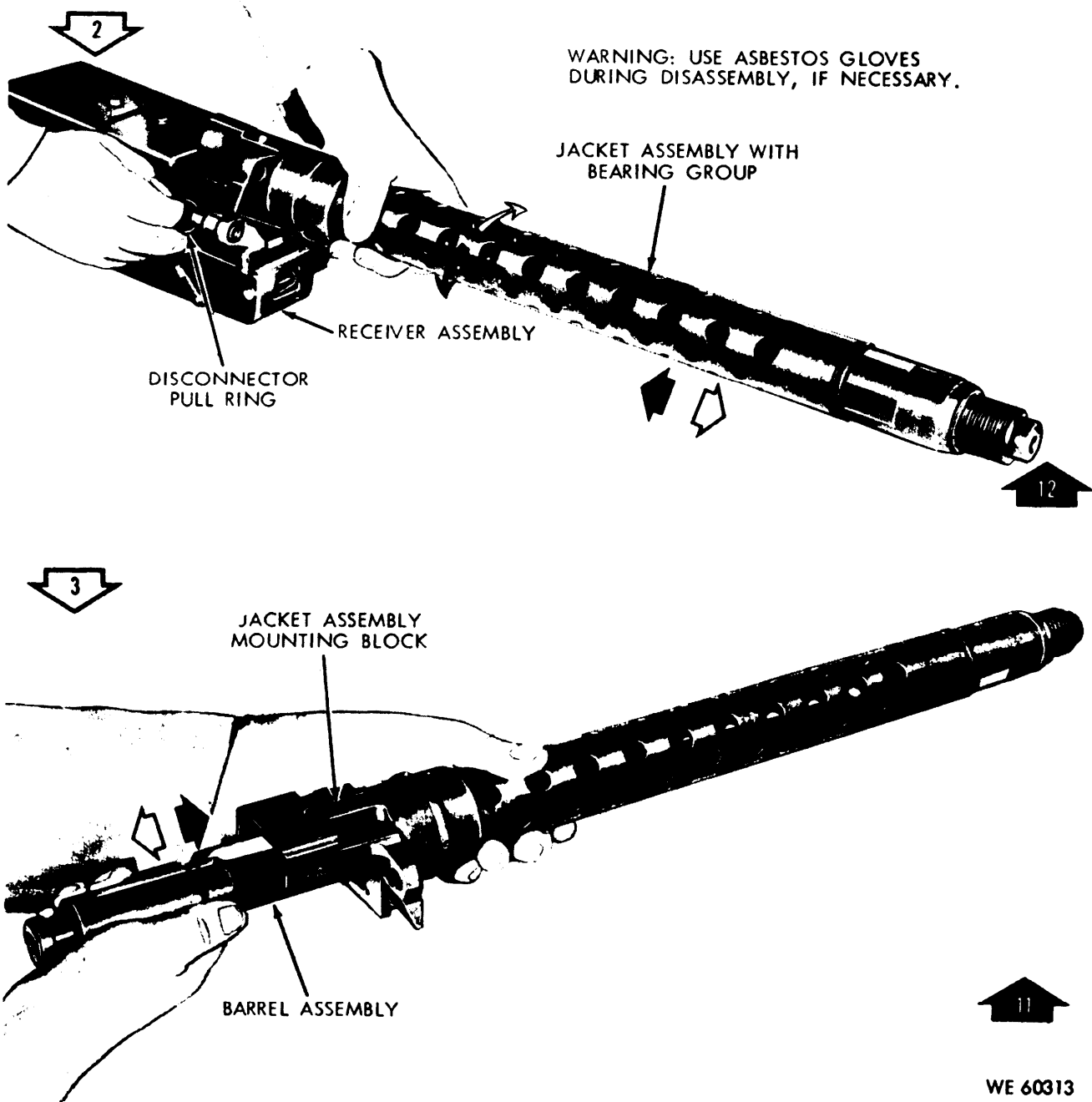
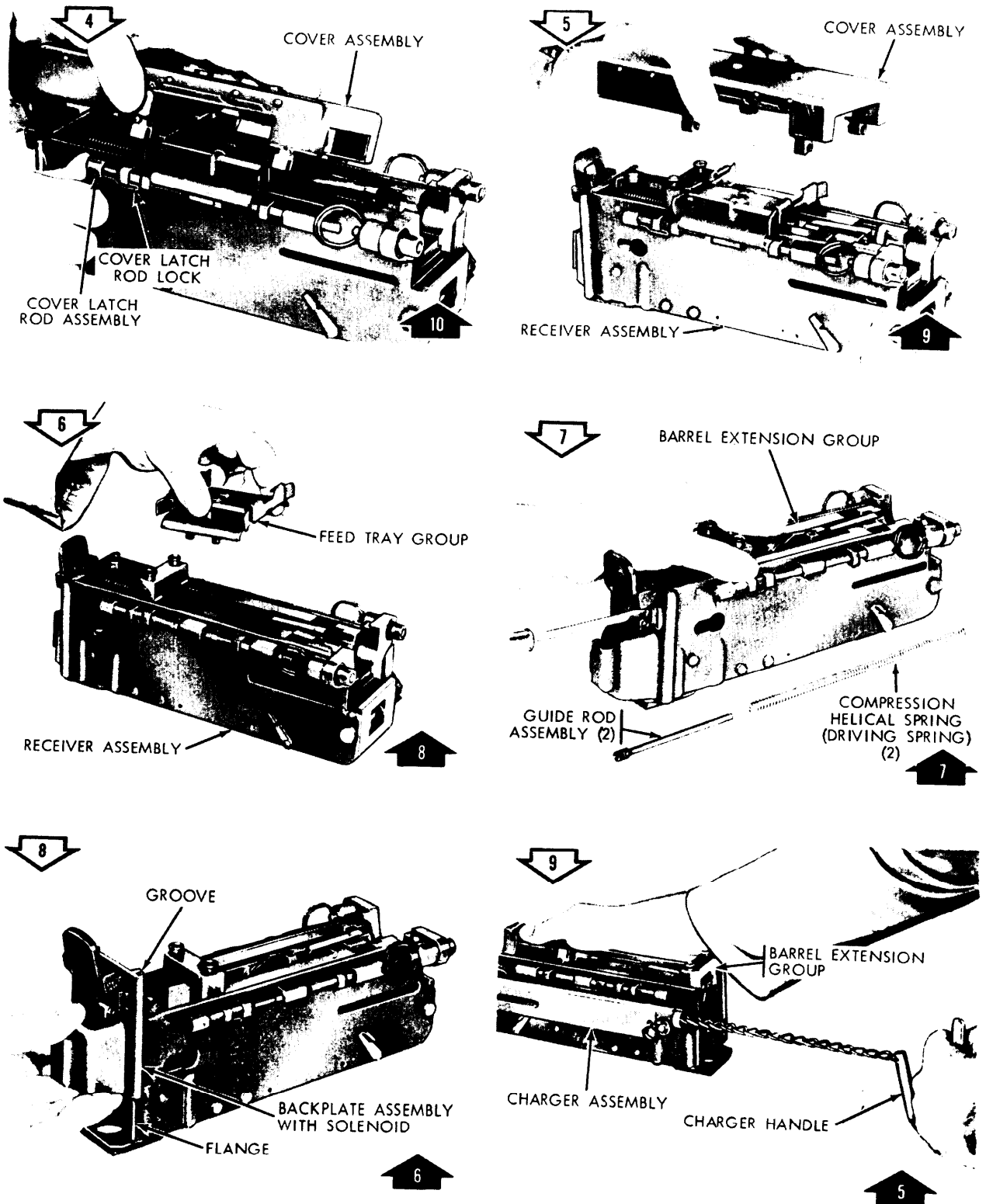

Figure 2-5. Disassembly / assembly of machine gun. (2 of 4)





WE 60314

Figure 2-6. Disassembly / assembly of machine gun. (3 of 4)

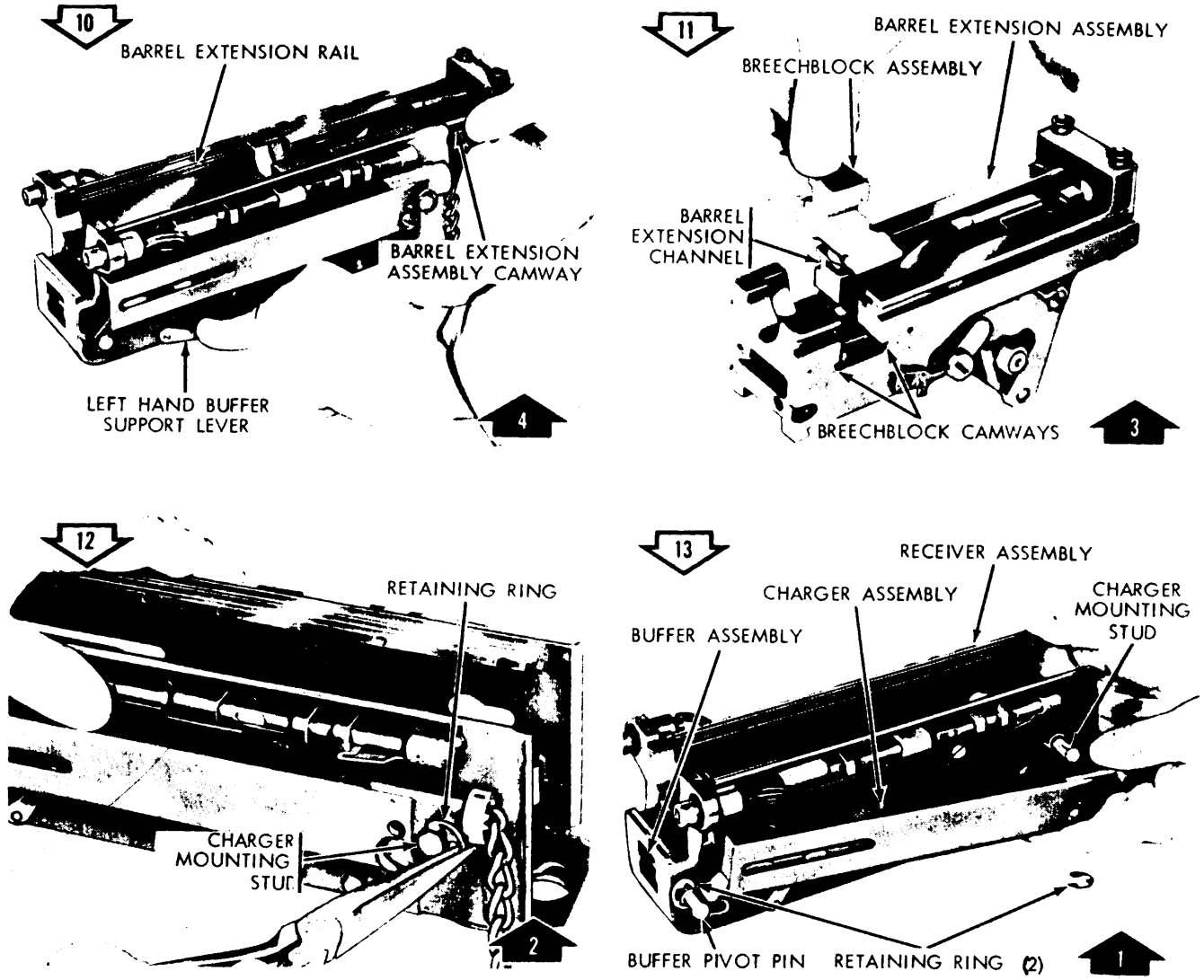
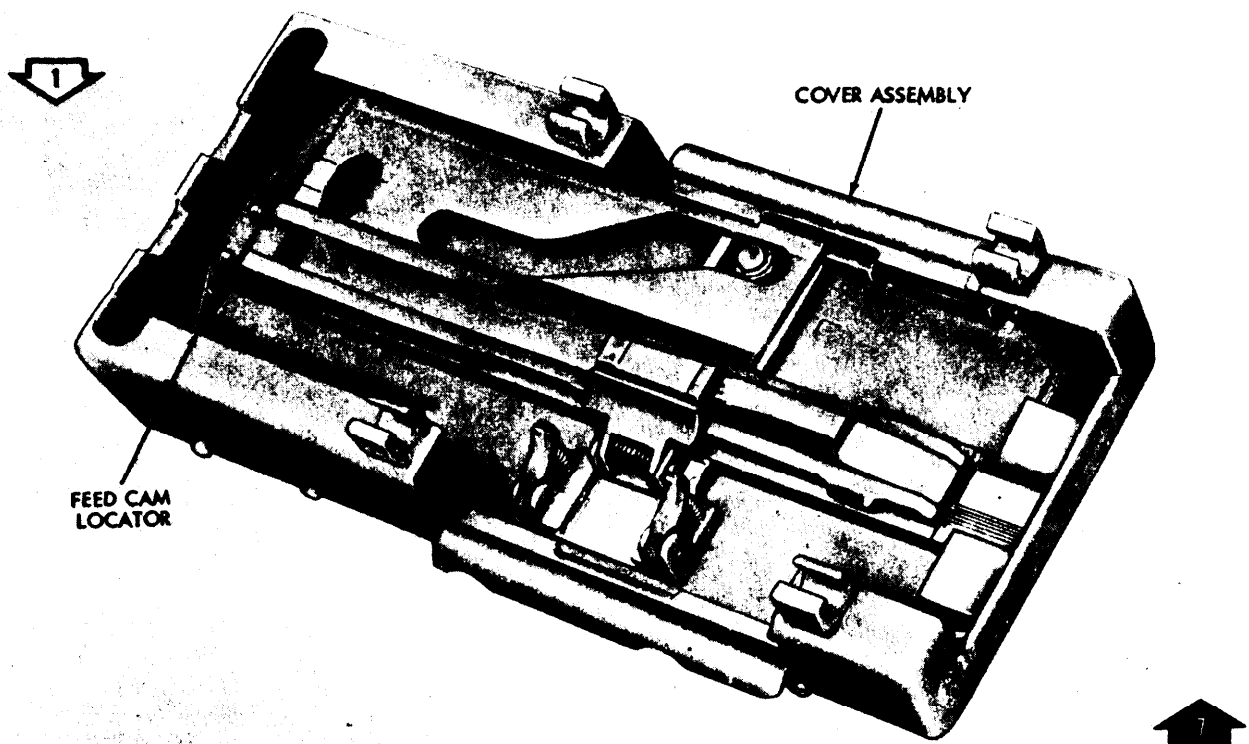
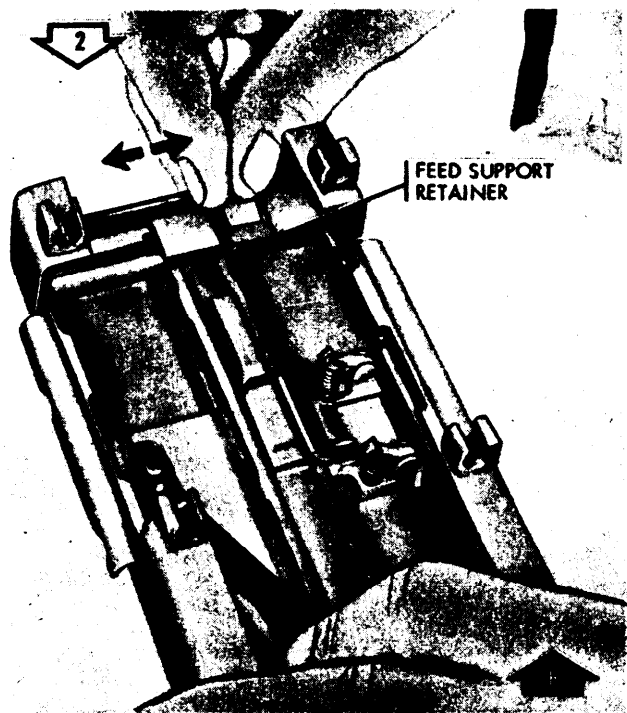

Figure 2-7. Disassembly / assembly of machine gun. (4 of 4)



COVER ASSEMBLY.



REMOVE/INSTALL FEED CAM.

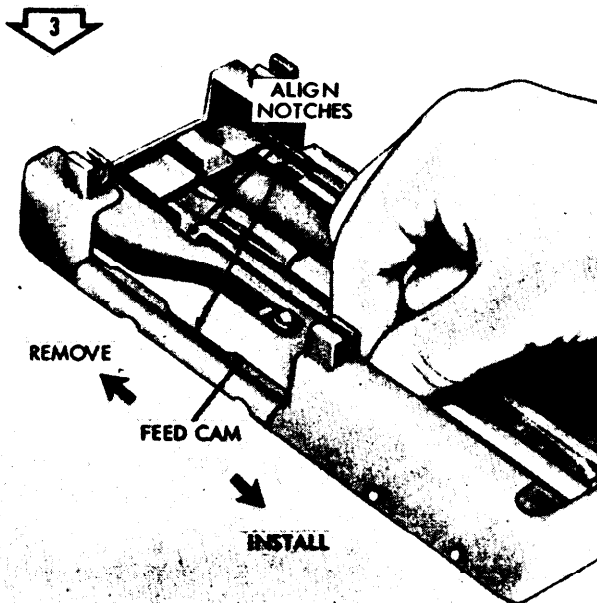

MOVE FEED SUPPORT RETAINER TO EXTREME RIGHT.

WE 15506

Figure 2-8. Disassembly / assembly of cover assembly. (1 of 2)



Figure 2-9. Disassembly/assembly of cover assembly. (2 of 2)

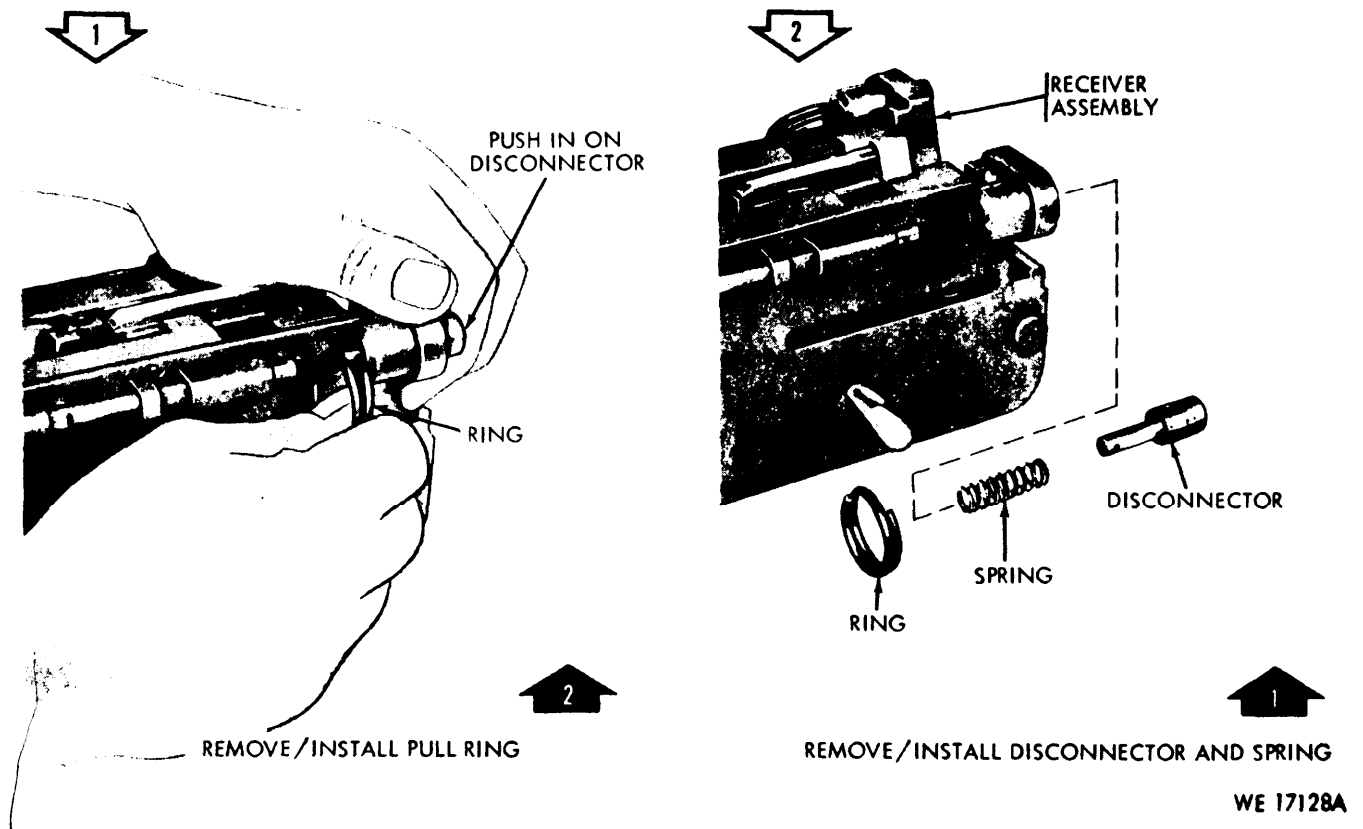

Figure 2-10. Disassembly/ assembly of receiver assembly.

**2-12. Cleaning, Inspection and Repair**

a. *Cleaning.*

**NOTE**

During periods of inactivity, clean and lubricate every 90 days unless inspection reveals more frequent servicing is necessary.

(1) Refer to paragraph 2-3b for cleaning materials used in conjunction but not issued with this equipment.

(2) For detailed cleaning procedures, refer to table 2-8.

(3) For additional cleaning data the following manuals contain a wealth of information: TM 9-208-1, Cleaning of Ordnance Materiel; and TM 9-247. Materials used for Cleaning, Preserving, Abrading and Cementing Ordnance Materiel; and Related Materials Including Chemicals.

*Table 2-8. Detailed Cleaning Procedures*

Step	Procedure
1	<p><b>NOTE</b></p> <p>The use of gasoline, kerosene, benzene (benzol) or high pressure water, steam, or air for cleaning the weapon is prohibited.</p> <p>Immediately after firing (or as soon as possible) thoroughly clean and lubricate the weapon to maintain reliability and combat effectiveness. Follow procedures listed below.</p>
2	<p><b>NOTE</b></p> <p>Do not dilute rifle bore cleaning compound (RBC). Do not add antifreeze. Shake well before using.</p> <p>Disassemble the machine gun into groups and assemblies.</p> <p><b>CAUTION</b></p> <p>Be careful not to use cleaning fluids or oil on back plate assembly to prevent contamination of the solenoid. Use clean cloths only.</p>

Table 2-8. Detailed Cleaning Procedures-Continued

Step	Procedure
3	Clean bore and chamber with brush or swab saturated with RBC until a clean swab can be run through the barrel without detecting any contamination. Wipe dry and lubricate.
4	Clean all metal surfaces that are subject to powder fouling with RBC, wipe dry and lubricate.
5	Clean all other surfaces not covered in steps 3 and 4 above, with SD or RBC, wipe dry and lubricate.
	<p style="text-align: center;"><b>CAUTION</b></p> <p><b>Dry cleaning solvent (SD) is flammable and should not be used near an open flame. Use only in well-ventilated areas. This solvent evaporates quickly and has a drying effect on the skin. When used without gloves it may cause cracks in the skin and in some cases mild irritation or inflammation.</b></p>
6	<p>on component parts which have a hard carbon residue it may be necessary to use carbon removing compound (P-C-111b). Observe the following procedures when using P-C-111b.</p> <p style="text-align: center;"><b>WARNING</b></p> <p><b>Avoid skin contact with P-C-111b. The compound should be washed off thoroughly with running water if it comes in contact with the skin. A good lanolin base cream, after exposure to compound, is helpful. The use of rubber gloves and protective equipment is recommended.</b></p> <ol style="list-style-type: none"> <li>(1) Using a suitable container, fill with fresh compound.</li> <li>(2) Before soaking parts in the compound, remove all loose dirt, grease, and oil. Place parts to be cleaned in the container, making certain they are completely immersed.</li> <li>(3) Depending on the amount of residue to be removed, between 2 and 16 hours soaking should be sufficient.</li> <li>(4) Rinse parts with water and SD, and brush with a stiff bristle brush.</li> <li>(5) Wipe parts dry and apply a light coat of oil to prevent rusting.</li> </ol> <p style="text-align: center;"><b>NOTE</b></p> <p>It is the responsibility of organizational maintenance to assure that weapons are clean prior to evacuating them to direct support maintenance for repair.</p>

**b. Inspection and Repair. Refer to table 2-9**

Table 2-9. Organizational Maintenance Procedures

Group or assembly	Inspection	Repair	Reference
<p>Machine gun</p> <p>Jacket assembly w / bearing group</p>	<p style="text-align: center;"><b>WARNING</b></p> <p>Before starting an inspection, be sure to clear the weapon. Do not actuate the trigger until the weapon has been cleared. Inspect the chamber to insure that it is empty, and check to see that no ammunition is in position to be introduced.</p> <p>Visually inspect machine gun for general appearance, condition and operation. Manual function, using dummy cartridges. Serial number must be legible. Inspect for burs and damage. Check for proper assembly. (See para 1-7 for differences.)</p> <p>Inspect flash hider / flash suppressor—must be secure and staked.</p> <p>Inspect jacket assembly for sharp edges and rough spots.</p> <p>Inspect barrel locator to insure it is secure in the mounting block.</p> <p>Inspect barrel bearing to insure it is tight against shoulder.</p> <p>Inspect barrel for damage. Barrels must be clean and free of corrosion such as may be caused by moisture and powder fouling.</p>	<p>Replace unserviceable components as authorized. Remove burs by stoning. Be careful not to change original configuration of components. Evacuate to direct support maintenance for repair beyond the scope of organizational maintenance.</p> <p>Replace items 2 and 4, fig C-1, if necessary. Evacuate to direct support maintenance for repair beyond the scope of organizational maintenance.</p>	<p>Fig 1-1 and C-1</p> <p>1, fig C-1</p>
<p>Cover assembly</p>	<p style="text-align: center;"><b>NOTE</b></p> <p>A clean bore is not necessarily a shiny bore, and frequently may have a dull gray appearance. A shiny, polished bore may indicate that abrasives have been used. Abrasives will NOT be used on the bore.</p> <p>Inspect action of feed cam, feed support assembly, feed slide and track assemblies, and retainer for proper function.</p> <p>Check spring action of depressor and stripper (4 and 5, fig C-3).</p> <p>Check spring action of pawls (12 and 19, fig C-3) of slide track assembly and feed slide assembly.</p> <p>Inspect to insure cover assembly locks securely on receiver.</p> <p>Inspect feed support assembly—pins shall not protrude into either side of cam slot.</p> <p>Inspect slide track assembly to insure pawls swing freely on pin. Pins must be secure.</p> <p>Inspect feed slide assembly to insure roller (17, fig C-3) turns freely.</p> <p>Inspect cover and track assembly (25, fig C-3)—rivets must be secure.</p>	<p>Replace item 10, fig C-3, if necessary. Evacuate to direct support maintenance for repair beyond the scope of organizational maintenance.</p>	<p>5, fig C-1 and fig C-3</p>

Table 2-9. Organizational Maintenance Procedures-Continued

Group or assembly	Inspection	Repair	Reference
Cover assembly (cont) Feed tray group	<p>Inspect all camming surfaces for damage.</p> <p>Inspect all components for cracks, breaks or damage. Welded areas must be secure.</p> <p>Inspect cartridge stop assembly—must be secure to feed tray assembly. Check for proper function of plunger 1 nd spring. Pin securing plunger to stop—must not be bent or distorted. Check to assure that plunger fits flush 1 nd does not protrude through under side of tray.</p> <p>Inspect feed tray assembly for proper fit on receiver. Rivets holding brackets to the under side of tray body must not be loose..</p>	<p>Replace item 6, fig C-4, if necessary.</p> <p>Evacuate to direct support maintenance for repair beyond the scope of organizational maintenance.</p>	6, fig C-1 and C-4
Guide rods	<p>Inspect to insure rods will lock securely to back plate assembly.</p> <p>Inspect rods to insure they are not bent. Check pins in rods for damage or looseness.</p>	<p>Evacuate to direct support maintenance for repair.</p>	8, fig C-1
Driving springs	<p>Inspect free length of driving springs—must be 8 inches or more in free length and both must be approximately the same length.</p>	<p>Replace if necessary.</p>	9, fig C-1
Back plate assembly w / solenoid	<p>Inspect back plate assembly fit on flanges of receiver. Make certain it fits securely and does not bind.</p> <p>Inspect spring action of trigger and sear, make certain they function properly.</p> <p>Inspect safety to insure it functions properly. Safety must positively prevent firing when in safe position.</p> <p>Inspect trigger spring pins--must be secure.</p> <p>Inspect solenoid yoke for staking. Lever (7, fig C-5) shall pivot freely without binding.</p> <p>Inspect for missing or loose pins.</p> <p>Inspect to insure nut shield is in place.</p>	<p>Evacuate to direct support maintenance for repair.</p>	10, fig C-1
Breechblock assembly	<p>Inspect breechblock assembly for proper fit in camways of barrel extension assembly—must slide freely.</p> <p>Inspect to insure roller moves freely.</p> <p>Inspect firing for spring action and for damage. Firing pin must protrude through face of breechblock.</p>	<p>Replace if necessary.</p>	12, fig C-1
Barrel extension assembly	<p>Inspect barrel extension assembly to insure it slides freely in camways of receiver.</p> <p>Inspect for proper function. Driving studs must not bind when depressed. Check rammer for freedom of movement.</p>	<p>Replace entire assembly, if necessary.</p> <p>Evacuate to direct support maintenance for repair.</p>	13, fig C-1
Charger assembly	<p>Inspect for loose pins and for cracked or missing rollers.</p> <p>Inspect to insure charger assembly is retained securely by the charger mounting stud and retaining ring.</p> <p>Inspect for proper fit of charger assembly to receiver.</p> <p>Inspect for loose or missing parts.</p>	<p>Evacuate to direct support maintenance for repair.</p>	16, fig C-1



Table 2-9. Organizational Maintenance Procedures—Continued

Group or assembly	Inspection	Repair	Reference
<p>Charger assembly (cont)</p> <p>Receiver assembly</p> <p>Reassembled machine gun</p>	<p>Inspect function of chain in slide, chain must travel smoothly when pulled and return to forward position when released. Links must not be damaged.</p> <p>Inspect receiver assembly visually for damage. Pay particular attention to the camways.</p> <p>Inspect spring action of rod assemblies (22, figs C-12 and C-13) for proper function. Cover latch assemblies must return to latched position under spring tension. inspect left and right buffer support levers for proper function. Must return to raised position under spring tension.</p> <p>Inspect breechblock cam for damaged camways. Camways must not have rough edges.</p> <p>Inspect retaining ring (4, figs C-12 and C-13)—must not be bent or distorted.</p> <p>Inspect disconnectors (8, figs C-12 and C-13) for spring action. Make certain they snap back in position.</p> <p>Inspect rate control slide for damage and proper function. Slide must return to rearward position under spring tension.</p> <p>H and cycle to insure proper functioning, use dummy ammunition.</p> <p>Inspect safety to insure it positively prevents trigger from being depressed when in safe position.</p> <p style="text-align: center;">NOTE</p> <p>If any repairs were made to machine gun, perform again those inspections indicated above for that group or assembly.</p>	<p>Replace items 4 and 9, figs C-12, and C-13 if necessary. Evacuate to direct support maintenance for repair beyond the scope of organizational maintenance.</p> <p style="text-align: center;">NOTE</p> <p>Repair of the receiver assembly at organizational maintenance will be limited to the replacement of parts authorized in appendix C, section II.</p>	<p>18, fig C-1 and figs, C-12 and C-13</p>



## CHAPTER 3

# DIRECT SUPPORT AND GENERAL SUPPORT MAINTENANCE INSTRUCTIONS

---

### Section I. REPAIR PARTS, SPECIAL TOOLS AND EQUIPMENT

#### 3-1. General

Repair parts, special tools, test, and support equipment are listed in appendix C.

### Section II. TROUBLESHOOTING

#### 3-2. General

Troubleshooting malfunctions, probable causes, and corrective actions for the machine guns are given in table 3-1.

*Table 3-1. Direct and General Support Troubleshooting*

Malfunction	Probable Cause	Corrective Action
1. Failure to feed	<ul style="list-style-type: none"> <li>a. Defective link or ammunition.</li> <li>b. Cover unlatched.</li> <li>c. Loading with barrel extension assembly in the forward position, round in feed tray slot and cover closed.</li> <li>d. Defective retaining (belt holding) pawl(s).</li> <li>e. Defective retaining pawl spring(s).</li> <li>f. Defective feed pawl.</li> <li>g. Defective feed pawl spring.</li> <li>h. Defective feed cam.</li> <li>i. Defective feed slide track.</li> <li>j. Defective feed slide assembly.</li> <li>k. Missing feed slide roller and retaining ring.</li> <li>l. Defective cover latch rod.</li> <li>m. Defective cover latch assemblies.</li> </ul>	<ul style="list-style-type: none"> <li>a. Remove faulty link and for round.</li> <li>b. Close cover.</li> <li>c. Load properly.</li> <li>d. Replace.</li> <li>e. Replace.</li> <li>f. Replace.</li> <li>g. Replace.</li> <li>h. Replace.</li> <li>i. Replace.</li> <li>j. Replace.</li> <li>k. Replace.</li> <li>l. Replace.</li> <li>m. Replace.</li> </ul>
2. Failure to chamber	<ul style="list-style-type: none"> <li>a. Defective ammunition.</li> <li>b. Ammunition belt installed upside down.</li> <li>c. Defective driving springs.</li> <li>d. Obstruction (foreign substance or material) in chamber.</li> <li>e. Defective cartridge depressor.</li> <li>f. Defective cartridge rammer (M73 only) or rammer and extractor assembly (M73A1 and M219 only).</li> <li>g. Defective cartridge stripper.</li> <li>h. Defective cartridge depressor spring.</li> <li>i. Defective cartridge stripper spring.</li> <li>j. Defective rammer actuator roller.</li> <li>k. Defective feed slide track assembly.</li> <li>l. Defective feed tray (6, fig. C-4).</li> </ul>	<ul style="list-style-type: none"> <li>a. Remove faulty round.</li> <li>b. Install belt properly (open sides of links facing downward).</li> <li>c. Replace.</li> <li>d. Remove obstruction.</li> <li>e. Replace.</li> <li>f. Replace.</li> <li>g. Replace.</li> <li>h. Replace.</li> <li>i. Replace.</li> <li>j. Replace.</li> <li>k. Replace.</li> <li>l. Replace.</li> </ul>

Table 3-1. Direct and General Support Troubleshooting—Continued

Malfunction	Probable Cause	Corrective Action
3. Failure to lock	<ul style="list-style-type: none"> <li>a. Defective firing pin extension.</li> <li>b. Defective driving springs.</li> <li>c. Defective barrel extension.</li> <li>d. Defective breechblock roller.</li> <li>e. Defective breechblock roller shaft.</li> <li>f. Defective or missing breechblock cam.</li> <li>g. Defective breechblock cam plunger spring.</li> </ul>	<ul style="list-style-type: none"> <li>a. Replace.</li> <li>b. Replace.</li> <li>c. Replace.</li> <li>d. Replace.</li> <li>e. Replace.</li> <li>f. Replace.</li> <li>g. Replace.</li> </ul>
4. Failure to fire	<ul style="list-style-type: none"> <li>h. Defective lever actuator roller.</li> <li>a. Defective barrel extension.</li> <li>b. Defective firing pin.</li> <li>c. Defective firing pin extension.</li> <li>d. Defective ammunition.</li> <li>e. Defective firing circuit.</li> <li>f. Defective hammer spring.</li> <li>g. Defective or missing rate control pawl.</li> <li>h. Defective or missing rate control pawl spring.</li> <li>i. Defective hammer sear.</li> <li>j. Faulty solenoid adjustment.</li> <li>k. Defective solenoid.</li> </ul>	<ul style="list-style-type: none"> <li>h. Replace.</li> <li>a. Replace.</li> <li>b. Replace.</li> <li>c. Replace.</li> <li>d. Replace.</li> <li>e. Check firing circuit.</li> <li>f. Replace.</li> <li>g. Replace.</li> <li>h. Replace.</li> <li>i. Replace.</li> <li>j. Adjust adenoid (para 4-3).</li> <li>k. Replace.</li> </ul>
<p>NOTE Inspect electrical harness.</p>		
5. Failure to unlock	<ul style="list-style-type: none"> <li>l. Defective rate control slide.</li> <li>m. Defective rate control slide spring.</li> <li>n. Faulty sear adjustment.</li> <li>a. Defective lever actuator roller.</li> <li>b. Defective barrel jacket.</li> <li>c. Loose barrel bearing.</li> </ul>	<ul style="list-style-type: none"> <li>l. Replace.</li> <li>m. Replace.</li> <li>n. Adjust properly (para 4-3).</li> <li>a. Replace.</li> <li>b. Replace.</li> <li>c. Reposition lock, tighten bearing and stake.</li> </ul>
6. Failure to extract	<ul style="list-style-type: none"> <li>a. Defective cartridge case (ruptured).</li> <li>b. Defective extractor (M73 only) or rammer and extractor assembly (M73A1 and M219 only).</li> <li>c. Defective cartridge rammer (M73 only).</li> <li>d. Defective extractor spring (M73 only).</li> <li>e. Pitted chamber.</li> <li>f. Short recoil.</li> </ul>	<ul style="list-style-type: none"> <li>a. Remove ruptured case.</li> <li>b. Replace.</li> <li>c. Replace.</li> <li>d. Replace.</li> <li>e. Inspect (table 4-1). Replace barrel assembly, if necessary.</li> <li>f. Investigate for binding parts. Clean and lubricate as required.</li> </ul>
7. Failure to eject	<ul style="list-style-type: none"> <li>a. Defective extractor (wings) (M73 only).</li> <li>b. Defective case carrier body (projections) (M73 only).</li> <li>c. Defective case carrier grips (M73 only).</li> <li>d. Defective case carrier grip inner and outer springs (M73 only).</li> <li>e. Round case grips assembled incorrectly (M73 only).</li> <li>f. Defective case carrier link assembly (M73 only).</li> <li>g. Defective feed tray (M73A1 and M219 only).</li> </ul>	<ul style="list-style-type: none"> <li>a. Replace.</li> <li>b. Replace.</li> <li>c. Replace.</li> <li>d. Replace.</li> <li>e. Assemble grips properly.</li> <li>f. Replace.</li> <li>g. Replace.</li> </ul>

Table 3-1. Direct and General Support Troubleshooting— Continued

Malfunction	Probable Cause	Corrective Action
8. Failure to cock	a. Defective hammer sear. b. Defective hammer. c. Defective hammer cocking roller. d. Defective hammer sear spring. e. Defective barrel extension.	a. Replace. b. Replace. c. Replace. d. Replace. e. Replace.
9. Uncontrolled fire	a. Defective barrel extension (sear notches). b. Defective trigger sear (hooks). c. Defective solenoid.	a. Replace. b. Replace. c. Replace.
10. Erratic firing rate	Loose rate control guide screw (15, figs C-12 and C-13) and rate control guide support screw (16, figs C-12 and C-13).	<b>NOTE</b> <b>Inspect electrical harness.</b> <b>Tighten screws and restake.</b>
11. Improper rate control	Missing rate control pawl.	Replace.
12. Excessive rearward movement (recoiling parts)	a. Buffer assembly (early design) installed upside down (M73 only). b. Defective buffer support spring. c. Faulty buffer adjustment.	a. Install buffer assembly properly. b. Replace. c. Adjust buffer (fig 4-3).
13. Failure to load	a. Feed components assembled incorrectly (cover assembly). b. Defective cover latch rod spring. c. Defective cover latch rod.	a. Assemble correctly (fig C-3). b. Replace. c. Replace.

**Section III. PREEMBARKATION INSPECTION OF MATERIEL IN UNITS ALERTED FOR OVERSEAS MOVEMENT**

**3-3. General**

This section provides specific instructions for guidance during inspection by direct and general support personnel of materiel in alerted units scheduled for overseas duty. Inspections are made for the purpose of:

- a. Determining serviceability.
- b. Recognizing conditions that would cause failure.
- c. Assuring proper maintenance at prescribed levels.
- d. Determining the ability of a unit to accomplish its maintenance and supply mission.

**3-4. Inspection Procedures**

**WARNING**

**Before starting an inspection, be sure to**

**clear the weapon. DO NOT actuate the trigger until the weapon has been cleared. Inspect the chamber to insure that it is empty, and check to see that no ammunition is in position to be introduced.**

- a. All parts and equipment issued to the vehicles for use on the machine gun must be examined for serviceability. Replace only defective items.
- b. Complete inspection of all parts is not always necessary. Good judgement should be exercised pertaining to the degree of inspection of integral parts within assemblies.
- c. Refer to TB9-1000-247-35 and table 3-2 for inspection criteria.

Table 3-2. Preembarkation Inspection

Item	Inspection Criteria
General	Inspect for overall appearance, proper finish, and proper function of machine gun and controls.
Jacket assembly w/ bearing group	Barrel locator must be secure in the mounting block. Barrel bearing must be tight, and lock should be staked to both jacket assembly and bearing.
Barrel assembly	Use barrel erosion gage kit 5910297. Refer to TM 9-4933-208-34. The lands forward of liner and at origin of rifling must not be burred, flattened, chipped, raised, sheared or stripped.
Backplate, driving springs, and guide rod group	Solenoid must be properly adjusted. Use flush pin sear gage 7799714 (para 4-3). Drivings springs must be 8 inches or more in length and both must be approximately the same length. Guide rods must not be bent.
Barrel extension group	Firing pin must protrude through face of breechblock when pressed. Rammer must not be bent.
Receiver assembly	Buffer assembly must be preloaded properly. Ejector must not be bowed inward on the M73 (M73A1 and M219 has no ejector on receiver]. Receiver weld cracks shall not exceed 3/8 inch in length.
Flash suppressor (for M60A1, M60A1E2 and M728 combat vehicles)	Inspect for straightness of bore and proper spacing of tangs with special plug gage 8440696.

**Section IV. GENERAL MAINTENANCE**

**3-5. General**

This section provides instructions on general maintenance procedures to be used by direct and general support maintenance in maintaining the machine gun.

**3-6. General Maintenance Repair Methods**

*a. Disassembly and Assembly Procedures.*

(1) In disassembling the machine gun, remove the major groups and assemblies. Groups and assemblies may be disassembled, as necessary, into individual parts. When it is necessary to disassemble a major group or assembly, refer to figures C-1 through C-13. Disassemble in numerical order, and assemble in reverse order.

(2) Complete disassembly of a unit is not always necessary in order to make a required replacement or repair. Good judgment should be

exercised to keep disassembly and assembly operations to a minimum.

(3) During assembly, assemblies and groups should be assembled first, then installed to form a complete unit. Lubricate rollers and sliding surfaces before assembly.

*b. Replacement of Parts.*

(1) Parts will be replaced when unserviceable.

(2) When assembling a unit, replace pins and cotter pins, if available. If screws, nuts, washers, and retainers are damaged they will be replaced.

(3) All springs will be replaced if they are broken, kinked, deformed, fail to function properly, or fail to meet specific requirements.

(4) If a new part is not available, a reconditioned part may be substituted. Such reconditioned parts should be examined carefully to determine their serviceability.

## CHAPTER 4

# REPAIR INSTRUCTIONS

---

### **4-1. General Maintenance**

Refer to paragraph 3-6.

### **4-2. Specific Repair Instructions**

Refer to table 4-1.

Table 4-1. Repair Instructions for Machine Gun

Group or assembly	Disassembly assembly	Inspection	Repair	Tests and adjustments
Machine gun	Fig C-1 and pertinent vehicle operator's manual	<p style="text-align: center;"><b>WARNING</b></p> <p><b>Before starting an inspection, be sure to clear the weapon. Do not actuate the trigger before the weapon has been cleared. Inspect the bore and chamber to insure that it is empty and free from obstructions. Check to see that no ammunition is in position to be introduced.</b></p> <p>Visually inspect machine gun for general appearance, condition and operation. Manual function, using dummy cartridges. Serial number must be legible.</p>	Repair or replace unserviceable components. Refinish components as necessary. Remove burr by stoning. Be careful not to change original configuration.	
Jacket assembly) w / bearing group	<p>1 thru 4, fig C-1, and fig C-2</p> <p style="text-align: center;"><b>CAUTION</b></p> <p>During assembly insure that parts are supported adequately to prevent damage to barrel jacket or bearing.</p>	<p>Inspect jacket assembly for sharp edges and rough spots. Inspect barrel locator to insure it is secure in the mounting block.</p> <p>Inspect barrel bearing to insure it is tight against shoulder. Barrel bearing lock must be staked securely into barrel jacket and bearing slots.</p> <p>Inspect barrel. Barrels must be clean and free of corrosion such as may be caused by moisture and powder fouling. The following determines the serviceability of the barrels:</p> <ol style="list-style-type: none"> <li>a. Pits in the chamber are allowable if they are not large enough to cause extraction difficulties.</li> <li>b. Pits as wide as a land or groove and three-eighths inch or less in length are allowable for 7.62-mm barrels. Conversely, pits greater than the width of a land or groove and more than three-eighths inch in length are cause for rejection.</li> <li>c. Scattered or uniformly fine pits are allowable.</li> <li>d. Tool marks or scratches are acceptable regardless of length. Tool marks will appear as lines running laterally in the grooves or may run spirally across the top of the lands.</li> <li>e. Definitely ringed bores or bores ringed sufficiently to bulge the outside surface of the barrel are cause for rejection. However, faint rings or shadowy depressions do not indicate an unserviceable barrel and should not be cause for rejection.</li> <li>f. Barrels will be rejected if worn sufficiently to affect sharpness of the lands. However, pits cutting into lands are acceptable if within the limitations described above.</li> <li>g. Lands that appear dark due to coating of gilding metal from projectiles should not be cause for rejection.</li> </ol>	<p>Replace items 2 and 4, fig. C-1 and items 1 thru 5, fig C-2, if necessary.</p> <p>Lock (4, fig C-2) will be staked securely into barrel jacket and bearing slots after assembly.</p>	Inspect barrel erosion with gage kit 5910297. Refer to TM 9-4933-208-34.



Table 4-1. Repair Instructions for Machine Gun—Continued

Group or assembly	Disassembly/ assembly	Inspection	Repair	Tests and adjustments
Jacket assembly w /bearing group (cont)		<p style="text-align: center;"><b>NOTE</b></p> <p>A clean bore is not necessarily a shiny bore and frequently may have a dull gray appearance. A shiny polished bore may indicate abrasives have been used. Abrasives will NOT be used on the bore.</p>		
Cover assembly	5, fig C-1 and fig C-3	<p>Inspect action of feed cam, feed support assembly, feed slide and track assemblies, and retainer for proper function.</p> <p>inspect spring action of depressor and stripper.</p> <p>Inspect spring action of pawls (12 and 19, fig C-3) of slide track assembly and feed slide assembly.</p> <p>Inspect to insure cover assembly locks securely on receiver.</p> <p>Inspect feed support assembly-pins shall not protrude into either side of cam slot.</p> <p>Inspect slide track assembly to insure pawls swing freely on pin. Pins must be secure.</p> <p>Inspect feed slide assembly to insure roller ( 17, fig C-3) turns freely.</p> <p>Inspect cover and track assembly (25, fig C-3) rivets must be secure.</p> <p>Inspect all caroming surfaces for damage.</p>	<p>Replace items 1, 3 thru 13, and 16 thru 25, fig C-3, if necessary. Pawl retaining pins (11, fig C-3) shall be lightly staked.</p> <p>If feed support retainer tabs are broken, refer to paragraph 4-6.</p>	
Feed tray group	6, fig C-1 and fig C-4	<p>Inspect all components for breaks or damage. Welded areas must be secure.</p> <p>Inspect cartridge stop assembly-must be secure to feed tray assembly. Check for proper function and tension of plunger and spring. Pin securing plunger to stop must not be bent or distorted. Check to insure that plunger fits flush and does not protrude through under side of tray.</p> <p>Inspect feed tray assembly for proper fit on receiver. Rivets holding brackets to the under side of tray body must not be loose.</p> <p>Minor cracks are permissible if they do not affect operation.</p>	<p>Replace items 1 thru 4, and item 6, fig C-4, if necessary.</p>	
Guide rods	8, fig C-1	<p>Inspect to insure rods will lock securely to back plate assembly.</p> <p>Inspect rods to insure they are not bent. Check pins in rods for damage or looseness.</p>	<p>Replace guide rods if necessary.</p>	
Driving springs	9, fig C-1	<p>Inspect driving springs for serviceability.</p>	<p>Replace driving springs if necessary.</p>	<p>Check length of driving springs. Springs must not be less than 8 inches long and must be</p>

Table 4-1. Repair Instructions for Machine Gun—Continued

Group or assembly	Disassembly assembly	Inspection	Repair	Tests and adjustments
Driving springs (cont)	10, fig C-1, and fig C-5	Inspect back plate assembly fit on flanges of receiver. Make certain it fits securely and does not bind. Inspect spring action of trigger and sear; make certain they function properly. Inspect safety to insure it functions properly. Safety must positively prevent firing when in safe position. Inspect trigger spring pins—must be secure. Inspect to insure solenoid fits properly in back plate assembly. Check solenoid yoke for staking. Lever (7, fig. C-5) shall pivot freely without binding.	Replace items 1 thru 14, fig C-5, if necessary. Trigger pivot pin must be flared at both ends after assembly. Yoke on solenoid shall be staked at both ends. If nut shield (10, fig C-5) is replaced, refer to figure 4-1 for procedures for forming. If trigger safety pin (13, fig C-5) is replaced, refer to figure 4-2 and paragraph 4-5 for procedure.	approximately the same length. Check solenoid for proper adjustment. Use flush pin gage 7799714. Refer to paragraph 4-3.
Breechblock assembly	12, fig C-1 and fig C-6	Inspect breechblock assembly for proper fit in camways of barrel extension assembly—must slide freely. Inspect to insure roller (6, fig C-6) moves freely. Inspect firing pin for proper spring action and for damage. Make certain firing pin protrudes through face of breech block.	Replace items 1 thru 7, fig C-6, if necessary. Entire assembly may be replaced if necessary.	
Barrel extension assembly	13, fig C-1 and figs C-7 thru C-10  During assembly of lever assembly, be careful not to assemble pins tightly enough to cause binding of rollers.	Inspect barrel extension assembly to insure it slides freely in camways of receiver. Inspect lever pivot pin for damage. Lever assembly must not bind on pin. Pin must be retained by detent in lever. Inspect case carrier link assembly (M73 only) for damaged or bent pins. Inspect case carrier assembly (4, fig C-7, and fig C-8) for damaged components (M73 only). Check case carrier grips for proper function and spring tension. Inspect lever assembly for damaged components. Rollers (3 and 6, fig C-9) must rotate freely without binding. Check lever pivot pin plunger and spring for tension and freedom of movement.	Replace items 1, 2, 3, 7, 9, thru 18, and 20 thru 26, fig C-7. Entire assembly may be replaced if necessary.  After assembly, hammer link (11, fig C-7) shall be staked at both ends. Hammer sear housing screw (18, fig C-7) shall be staked in either cavity after assembly.  Replace items 1 thru 6, fig C-8, if necessary. Replace items 1 thru 10, fig C-9, if necessary. Replace items 1 thru 7, fig C-10, if necessary.  Pin (4, fig C-10) will be staked in 2 places both sides after assembly.	
		Inspect rammer assembly for damaged components. Firing pin extension must slide freely within rammer. Check end to insure it is not damaged. Check firing pin spring for weakness. Check extractor pins to insure they are secure. Inspect end of extractor for damage and chips. Extractor must not be bent. Check extractor and spring for proper movement. Inspect rammer for		

Table 4-1. Repair Instructions for Machine Gun —Continued

Group or assembly	Disassembly/ assembly	Inspection	Repair	Tests and adjustments
Barrel extension assembly (cont)		<p>damage, paying particular attention to the camways. Check pin (4, fig C-10) for secure staking in 2 places, both sides.</p> <p>Inspect hammer assembly parts. Roller must rotate freely without binding. No looseness is permitted between screw, link and hammer. Inspect hammer for damaged notches and for fit on link. Inspect link (11, fig C-7) for secure staking on both sides.</p> <p>Inspect rate control pawl for damage. The protruding stud and pawl must not be bent.</p> <p>Inspect the hammer sear housing screw for staking. Threads must not be damaged.</p> <p>Inspect for bent or damaged hammer sear. Make certain sear fits freely in sear housing.</p> <p>Inspect hammer sear housing for cracks or damage. Threads must not be damaged. Check housing stud for serviceability. Inspect driving stud springs for damage.</p>		
Charger assembly	Fig C-11	<p>Inspect to insure charger assembly is retained securely by the charger mounting stud retaining ring.</p> <p>Inspect for proper fit of charger assembly to receiver.</p> <p>Inspect to assure self-locking screws (2, fig C-11) hold bracket to connector.</p> <p>Inspect charger spring guide, spring must slide freely in guide. Check spring for bends and kinks.</p> <p>Inspect roller (5, fig. C-11) for damage.</p> <p>Inspect charger assembly slide for damage. Pay particular attention to the lips—must not be jagged. Check function of chain in slide.</p> <p>Inspect connecting link components (10, fig C-11) for damage. Retainer must hold link together securely.</p> <p>Inspect chain for damage. Check for smooth action of chain when pulled.</p> <p>Inspect housing for damage paying particular attention to the holes.</p> <p>Inspect pin ( 14, fig C-11) for flaring on both sides.</p>	<p>Replace items 1 thru 16, except 11, fig C-11 as necessary. Item 11 is manufactured from bulk issue item 819880 (see section IV of appendix C). Handle pin (14, fig C-11) will be flared on both sides after assembly.</p>	
Receiver assembly	Figs C-12 and C-13 If buffer assembly or recoil mechanism buffer is disassembled for any reason, when reassembled it must be preloaded.	<p>Inspect receiver assembly visually for damage, cracks, loose welds or parts, and general serviceability.</p> <p>Inspect spring action of rod assemblies (22, figs C-12 and C-13) for proper function. Cover latch assemblies must return to latched position under spring tension.</p> <p>Inspect left and right buffer support levers for proper function. Must return to raised position under spring tension.</p> <p>Inspect pin holes for elongation and burs.</p>	<p>Replace items 1 thru 24, 26, 28 and 29, figs C-12 and C-13. Items 28 and 29 are authorized to general support maintenance only.</p>	

**Table 4-1. Repair Instructions for Machine Gun —Continued**

Group or assembly	Diaassembly/ assembly	Inspection	Repair	Tests and adjustments
Receiver assembly (cont)	Preload by tightening nut $\frac{3}{4}$ to 1 turn beyond initial contact with springs (fig 4-3).	<p>Inspect breechblock cam for damaged camways. Camways must not have rough edges.</p> <p>Inspect retaining ring (4, fig C-12 and C-13)—must not be bent or distorted.</p> <p>Inspect buffer pivot pin for damage—pin must not be bent.</p> <p>Inspect buffer assembly (M73 only) and recoil mechanism buffer (M73A1 and M219 only) for dam age. Pay particular attention to the lugs. Check to insure buffer assembly is secure to receiver assembly.</p> <p>Inspect pull rings (7, figs C-12 and C-13) for damage or distortion.</p> <p>Inspect disconnectors by actuating them. Make certain they snap back in position.</p> <p>Inspect buffer support levers for damage or distortion. Buffer support spring must not be bent or distorted.</p> <p>Inspect rate control slide for damage and proper function. Slide must return to rearward position under spring tension.</p> <p>Inspect rate control guide-shaft must be straight.</p> <p>Inspect rate control guide screw and rate control guide support screw to insure they are secure and staked.</p> <p>Inspect cover latch assemblies (24, figs C-12 and C-13) for damage or distortion.</p> <p>Inspect pins (21, figs C-12 and C-13) for staking—pins should be staked in 2 places on both sides.</p> <p>Inspect shell assembly for damage, cracks, and general serviceability. Cracks must not be over <math>\frac{3}{8}</math> inch long. Check camways for damage.</p> <p>Hand cycle to insure proper functioning; use dummy ammunition.</p> <p>Inspect safety to insure it positively prevents trigger from being depressed.</p> <p style="text-align: center;"><b>NOTE</b></p> <p>If any repairs were made to machine gun, perform again those inspections indicated above for that group or assembly.</p>	<p>After assembly, rate control guide screw and rate control guide support screw (15 and 16, figs C-12 and C-13) must be staked securely into screw slot without damaging receiver. After assembly of pins (21, fig C-12 and C-13), stake pins in 2 places both sides after assembly.</p>	
Reassembled machine gun				

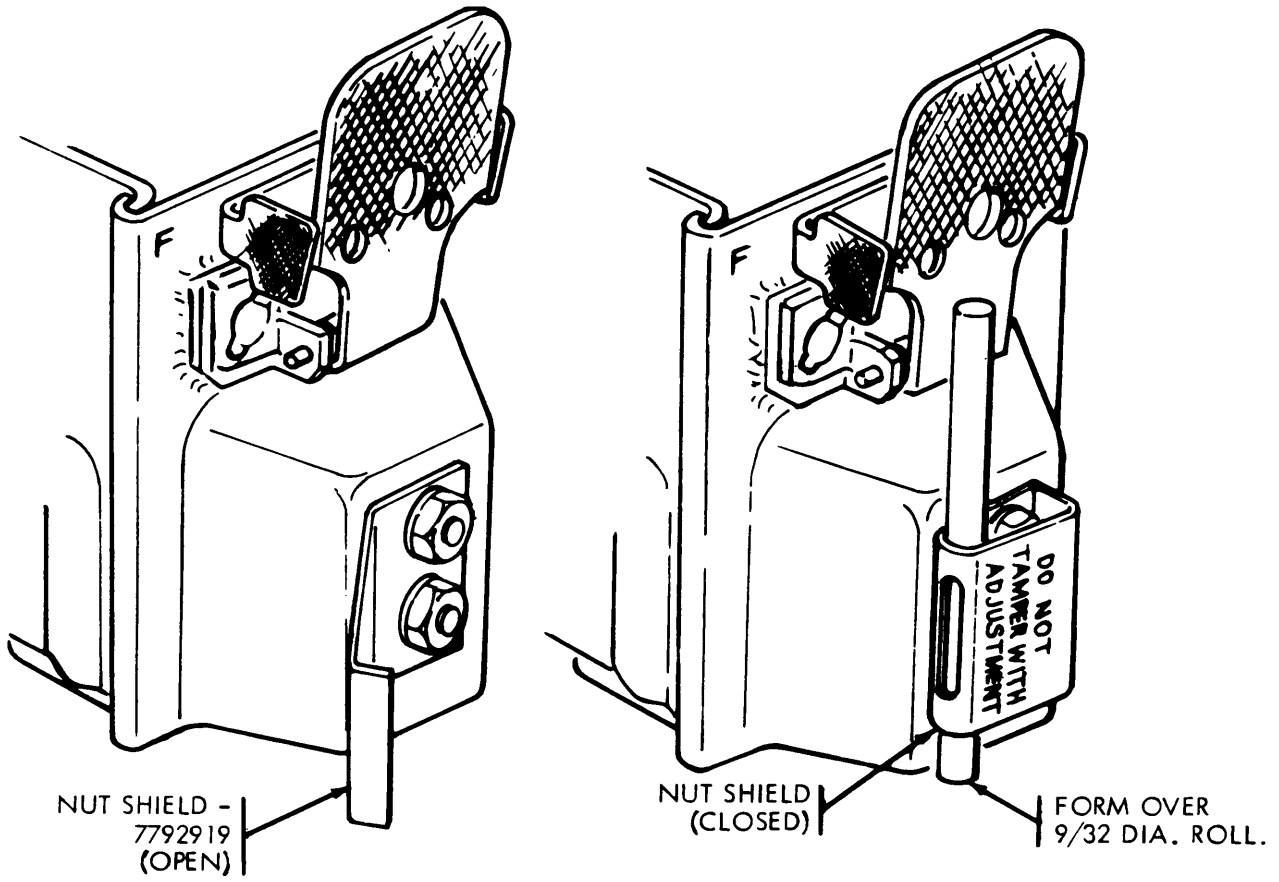

WE 10047A

Figure 4-1. Forming nut shield.

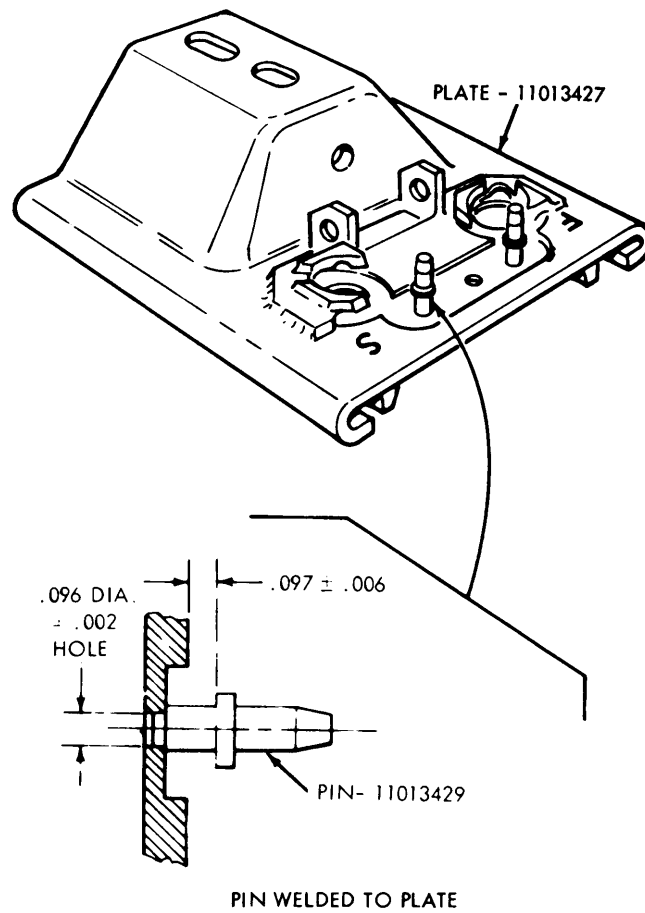

WE 69793

Figure 4-2. Replacing trigger safety pin 11013429.

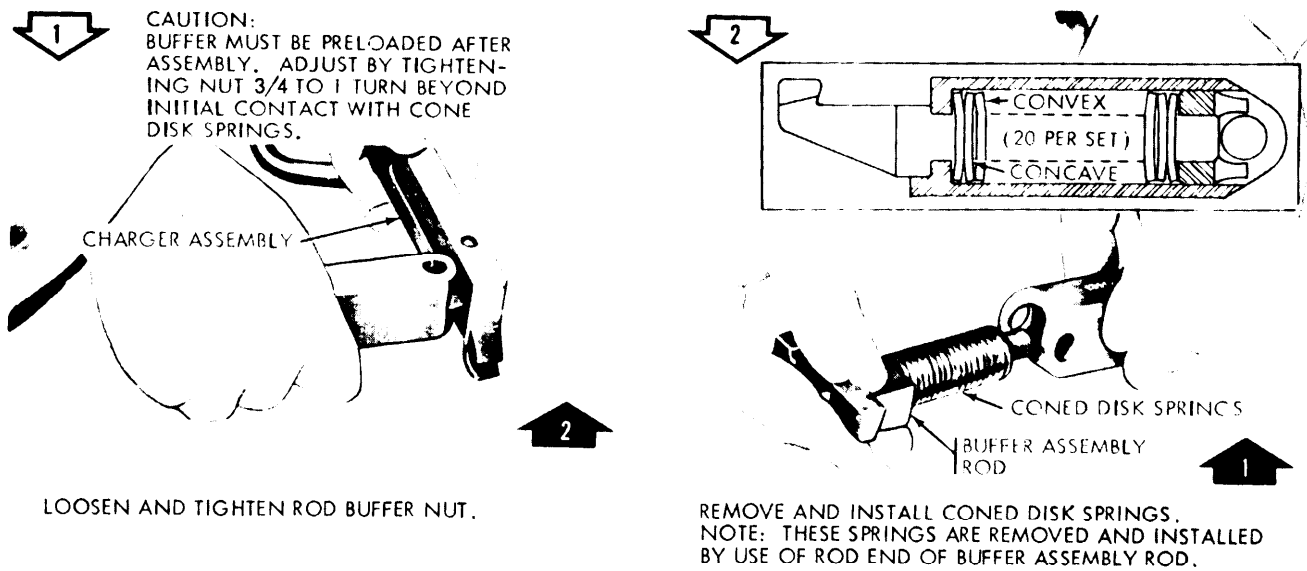

WE 69497

Figure 4-3. Preloading buffer assembly.

### 4-3. Adjustment of Solenoid

If solenoid nuts are loose, solenoid adjustment of the back plate assembly is necessary, using the following procedures:

**NOTE**

Latest design back plates, with nut, will be adjusted in the same manner.

- a. Place the safety in the safe "S" position.
- b. Apply pressure on the trigger and solenoid to eliminate any play between the safety and sear, and tighten the solenoid nuts securely.

**NOTE**

At times, tightening the solenoid nuts will create excessive interference between the safety and the sear. If this occurs, difficulty will be encountered when sliding the safety from the fire "F" into the safe "S" position. Repeat adjustment, b, above, until safety is operational.

- c. Move the safety from side to side then back into the safe position. There should be a slight interference between the contact area of the safety and the sear. To determine the proper adjustment of back plate assembly a flush pin sear gage 7799714 is utilized as follows:

(1) Place gage on tracks and position plunger over the sear hooks as indicated in figure 4-4.

(2) With safety in the FIRE position apply a slight pressure to gage plunger pins—do NOT energize the solenoid. The readings must be within the high and low ranges as shown in figure 4-4.

**NOTE**

The lowest surface of the plunger must be flush or below the gage surface, while the medium height surface must be flush or above. Check bolt plungers.

- d. The back plate adjustment is complete when checkout procedures are applied as follows:

(1) Assemble the weapon completely and set the safety in FIRE position. Charge the weapon and manually depress the trigger. Sear must release the barrel extension.

(2) Charge weapon, with safety in FIRE position, set the safety in SAFE position and energize the solenoid to depress the sear. Sear must not release the barrel extension.

(3) Repeat operations (1) and (2) three times.

(4) Snap the safety into FIRE position and charge the weapon. Agitate the receiver. Sear must not release the barrel extension.

(5) Install gage as indicated in c(1), set safety in SAFE position. Energize the solenoid. The top surface of the gage plungers must be flush or above the gage surface as shown in figure 4-4.

**CAUTION**

Do NOT interchange back plate assemblies without checking sear height. If back plate assemblies are interchanged without checking sear height, a runaway gun may result.

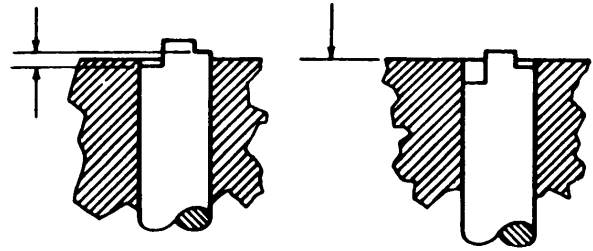

HIGH AND LOW RANGE WITH SAFETY IN FIRE POSITION

ACCEPTABLE RANGE WITH SAFETY IN SAFE POSITION AND SOLENOID ENERGIZED

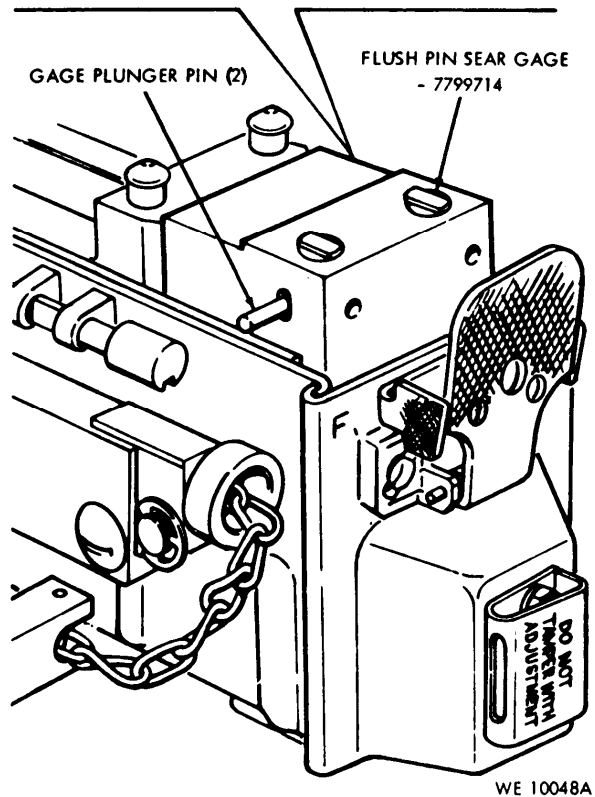

Figure 4-4. Checking height of sear hooks.

### 4-4. Repair of Receiver Assembly

A machine gun exhibiting cracked welds in the rails and cover latch rod brackets can be repaired by rewelding the side rails to the shell assembly.

These procedures are limited to general support maintenance personnel.

a. The following procedures will be followed in the welding of these components:

(1) Thoroughly clean the areas to be welded with a file, grinder, or wire brush, to provide a clean surface for welding.

(2) Weld a 1/8-inch continuous bead in the areas as indicated in figure 4-5. Refer to paragraph 4-5 for equipment to be used for welding.

(3) Check receiver assembly with barrel extension assembly to insure that there is no distortion or binding during operation.

b. Shell assemblies exhibiting cracked welds in excess of 1/8-inch and up to 3/8-inch in length longitudinally can be rewelded utilizing the above procedures after grinding a V-groove through the length of the cracked welds for metal retention.

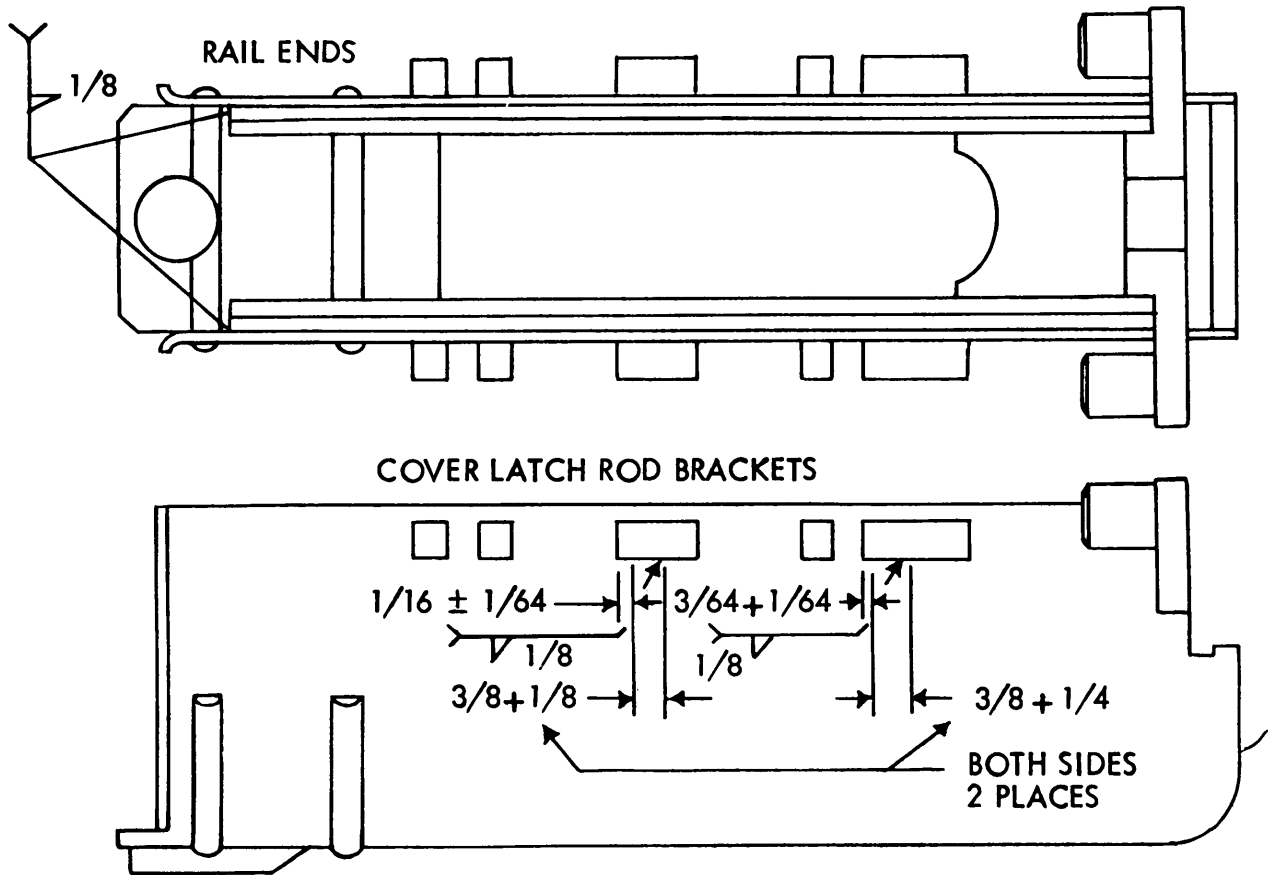

WE 69474

Figure 4-5. Repair of shell assembly.

**4-5. Welding**

a. Use Gasoline Engine Driven Arc Welder, contained in Shop Equipment Set, Welding, Field Maintenance FSN 3470-357-7268. Use rod, welding FSN 3439-902-4209, 3439-910-4007 or 3439-902-4208 with above welder. These welding rods are available in the Supply System and are the ONLY rods authorized to weld weapon with Non-Inert Gas Welding Machines.

b. If available, the Arc Welding Machine, General and Inert Gas (Line Item Y47707, SB

700-20) can be used as an alternate method, When using this machine, use bore 3/32 stainless steel welding rod MIL-E-19933 (Type MIL-310).

**4-6. Repair of Cover and Track Assembly**

Covers with broken feed support retainer tabs may be reclaimed by installing rivet MS 51931-4 and attaching as indicated in figure 4-6. If necessary protrusion of rivet may be adjusted (optional-file or machine) for the stop/interference of the feed support retainer.



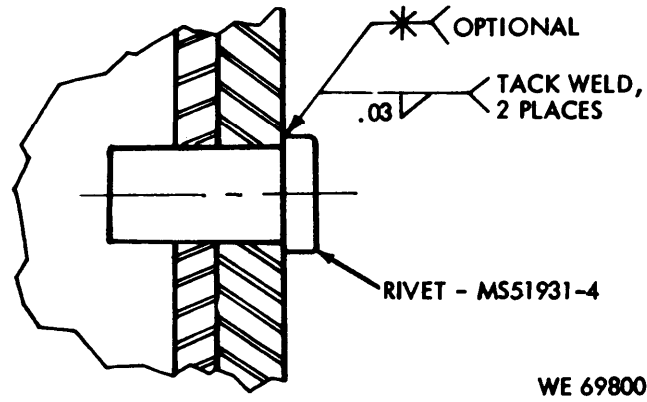

*Figure 4-6. Repair of cover and track assembly.*



## CHAPTER 5

### FINAL INSPECTION

**5-1. General**

The equipment must function properly, have all defects corrected, and be in a usable condition before return to troops or stock.

**5-2. Inspection and Procedures**

Refer to table 5-1.

**5-3. Functioning and Firing Tests**

a. Machine guns that have been repaired should be fired whenever possible, to assure proper operation. Ten rounds of ball ammunition should be sufficient to test the gun. Ten dummy rounds—fed by hand—will be functioned tested in the machine gun prior to the firing test. Equipment that fails to fire satisfactorily or function and meet

inspection criteria will be corrected by replacement of defective components.

b. Upon completion of testing, the equipment will be properly cleaned (para 2-12a) and lubricated (para 2-4 thru 2-6).

c. After cleaning and lubricating the machine gun will be assembled for left hand feed (para 2-2a) and the charger assembly will be assembled on the left side of the receiver (para 2-2b).

**5-4. Completion of Inspection**

Upon completion of inspection and the equipment has been restored to a completely serviceable condition, it shall be stated that the weapon is acceptable for “return to user” or for “return to stock”.

*Table 5-1. Final Inspection*

Component or Assembly	Point or item of Inspection	Method of Inspection	Acceptable Condition
Machine Gun		Visual	Complete and serviceable weapon, assembled for left hand feed, with all modifications applied.
	Exposed metal surfaces	Visual	Dull, rust resistant finish, free from burs and deep scratches.
	Barrel	Visual	Clean, free of rust and powder fouling, bulges and rings.
	Serial number	Visual	Legible.
	All assemblies	Functional	Check for looseness or play.
			<b>NOTE</b> Check to make certain the proper barrel extension assembly and other peculiar parts are in the different models as required (para 1-7).
Jacket assembly	Bearing and lock Barrel locator	Visual	Must be secure to receiver.
		Visual	Must be secure to barrel jacket and properly staked.
Cover assembly and feed tray group		Functional	Functions properly.
Guide rod assemblies		Visual	Must fit firmly in place on receiver assembly. Brackets must mate properly with slots on receiver assembly.
Back plate assembly		Visual	Must be secure to back plate brackets. Must fit properly to rear of receiver. Nut shield must be secure.
Charger assembly	Front bracket	Visual	Must be secure to buffer pivot pm.
	Rear portion	Visual	Must be fastened and held by the retaining rings.
	Spring action	Functional	Must function properly—return to forward position.
Cover latch rod assemblies and spring		Functional	Must function.
Disconnecter grips		Functional	Actuate must snap back into position.
Trigger		Functional	Must function.
Safety		Functional	Must function.
Buffer support	Right and left levers	Functional	Must function.



## APPENDIX A

## REFERENCES

**A-1. Publication Indexes**

Consult the following publication indexes frequently for the latest changes or revisions of references and for new publications relating to materiel covered in this manual.

Index of Administrative Publications . . . . .	DA Pam 310-1
Index of Army Motion Pictures and Related Audio Visual Aids . . . . .	DA Pam 108-1
Index of Blank Forms . . . . .	DA Pam 310-2
Index of Doctrinal, Training, and Organizational Publications . . . . .	DA Pam 310-3
Index of Supply Catalogs and Supply Manuals (excluding types 7, 8, and 9). . . . .	DA Pam 310-6
Index of Technical Manuals, Technical Bulletins, Supply Manuals (types 7, 8, and 9) Supply Bulletins, and Lubrication Orders . . . . .	DA Pam 310-4
U. S. Army Equipment Index of Modification Work Orders . . . . .	DA Pam 310-7

**A-2. Forms**

DA Form 2028, Recommended Changes to Publications.

**A-3. Other Publications**

The following explanatory publications pertain to this material.

Accident Reporting and Records . . . . .	AR 385-40
Administrative Storage of Equipment . . . . .	TM 740-90-1
Ammunition, General . . . . .	TM 9-1300-200
Authorized Abbreviations and Brevity Codes . . . . .	AR 310-50
Care, Handling, Preservation, and Destruction of Ammunition . . . . .	TM 9-1300-206
Cleaning of Ordnance Materiel. . . . .	TM 9-208-1
Dictionary of United States Army Terms (Short Title, AD) . . . . .	AR 310-25
DS and GS Maintenance Manual: Kits, Barrel Erosion Gage, M8 and M6A1 . . . . .	TM 9-4933-208-34
Malfunctions Involving Ammunition and Explosives . . . . .	AR 75-1
Materials Used for Cleaning, Preserving, Abrading, and Cementing Ordnance Materiel: and Related Materials Including Chemicals . . . . .	TM 9-247
Military Symbols . . . . .	FM 21-30
Procedures for Destruction of Equipment in Federal Supply Classifications 1000, 1005, 1010, 1015, 1020, 1025, 1030, 1055, 1090, and 1095, to Prevent Enemy Use . . . . .	TM 750-244-7
Standards for Oversea Shipment or Domestic Issue of Small Arms, Aircraft Armament, Towed Howitzers, Mortars, Recoilless Rifles, Rocket Launchers and Associated Fire Control Equipment . . . . .	TB9-1000-247-35
The Army Maintenance Management System (TAMMS) . . . . .	TM 38-750



# APPENDIX B

## MAINTENANCE ALLOCATION CHART

---

### Section I. INTRODUCTION

#### B-1. General

The maintenance allocation chart indicates specific maintenance operations performed at the proper maintenance levels. Deviation from maintenance operations allocated in the chart is authorized only upon approval of the Commanding Officer.

#### B-2. Maintenance Functions

Maintenance functions shall be limited to and defined as follows:

a. *Adjust*. Maintain within prescribed limits by bringing into proper or exact position, or by setting the operating characteristics to the specified parameters.

b. *Align*. To adjust specified variable elements of an item to bring about optimum or desired performance.

c. *Calibrate*. To determine and cause corrections to be made or to be adjusted on instruments or test measuring and diagnostic equipment used in precision measurement. Consists of comparison of two instruments, one of which is a certified standard of known accuracy, to detect and adjust any discrepancy in the accuracy of the instrument being compared.

d. *Inspect*. To determine the serviceability of an item by comparing its physical, mechanical, and/or electrical characteristics with established standards through examination.

e. *Install*. The act of emplacing, seating, or fixing into positions an item, part, module (component or assembly) in a manner to allow the proper functioning of the equipment/ system.

f. *Overhaul*. That maintenance effort (service/action) necessary to restore an item to a completely serviceable/operational condition as prescribed by maintenance standards (e.g. DMWR) in pertinent technical publications. Overhaul is normally the highest degree of maintenance performed by the Army. Overhaul does not normally return an item to like new condition.

g. *Rebuild*. Consists of those services/actions necessary for the restoration of unserviceable equipment to a like-new condition in accordance with original manufacturing standards. Rebuild is the highest degree of materiel maintenance applied

to Army equipment. The rebuild operation includes the act of returning to zero those age measurements (hours, miles, etc.) considered in classifying Army equipment/ components.

h. *Repair*. The application of maintenance services (inspect, test, service, adjust, align, calibrate, replace) or other maintenance actions (welding, grinding, riveting, straightening, facing, remachining, or resurfacing) to restore serviceability to an item by correcting specific damage, fault, malfunction, or failure in a part, subassembly, module / component / assembly, end item or system.

i. *Replace*. The act of substituting a serviceable like-type part, subassembly, module (component or assembly) in a manner to allow the proper functioning of an equipment/system.

j. *Service*. Operations required periodically to keep an item in proper operating condition, i.e., to clean, preserve, drain, paint, or to replenish fuel / lubricants / hydraulic fluids or compressed air supplies.

k. *Test*. To verify serviceability and to detect incipient failure by measuring the mechanical or electrical characteristics of an item and comparing those characteristics with prescribed standards.

l. *Symbols*. The uppercase letter placed in the appropriate column indicates the lowest level at which that particular maintenance function is to be performed.

#### B-3. Explanation of Format

Purpose and use of the format are as follows:

a. *Column 1, Group Number*. Column 1 lists group numbers, the purpose of which is to match components, assemblies, subassemblies and modules with the next higher assembly.

b. *Column 2, Functional Group*. Column 2 lists the next higher assembly group and the item names of components, assemblies, subassemblies and modules within the group for which maintenance is authorized.

c. *Column 3, Maintenance Function*. Column 3 lists the eleven maintenance functions defined in B-2 above. Each maintenance function required for an item shall be specified by the symbol among those listed in d below which indicates the level responsible for the required maintenance. Under

this symbol there shall be listed an appropriate work measurement time value determined as indicated in e below.

d. *Use of Symbols.* The following symbols shall be used to prescribe work function responsibility:

- C - Operator/ Crew
- O - Organizational
- F - Direct Support
- H - General Support
- D - Depot

e. *Work Measurement Time.* The active repair time required to perform the maintenance function is included directly below the symbol identifying the category of maintenance. These figures were developed under conditions corresponding to those that are normal for TOE units operating in the field. The skill levels used to obtain the measurement times are approximate of those in

typical TOE units. Active repair time is the average aggregate time required to restore an item (subassembly, assembly, component, module, end item or system) to a serviceable condition under typical field operating conditions. This time includes preparation time, fault isolation / diagnostic time, and QA / QC time. It also includes the time required to perform specific maintenance functions identified for the tasks authorized in the maintenance allocation chart. This time is expressed in man-hours and carried to one decimal place (tenths of hours).

f. *Column 4, Tools and Equipment.* This column shall be used to specify, by code, those tools and test equipment required to perform the designated function.

g. *Column 5, Remarks.* Self-explanatory.

## Section II. MAINTENANCE ALLOCATION CHART FOR MACHINE GUNS, 7.62-MM, M73, M73A1 and M219

(1) Group No.	(2) Functional group Component Assembly Nomenclature	(3) Maintenance functions										(4) Tools and equipment	(5) Remarks	
		Inspect	Test	Service	Adjust	Align	Calibrate	Install	Replace	Repair	Overhaul			Rebuild
1	Jacket assembly w/ bearing group	C	-	C	-	-	-	C	-	O	D	-		
		0.1		0.1				0.2		0.3	2.0			
1a	Barrel assembly	C	-	C	-	-	-	C	C	-	-	-		
		0.2		0.1				0.1	0.1					
2	Cover assembly	C	-	C	-	-	-	C	-	O	D	-		
		0.2		0.1				0.1		0.5	2.0			
3	Feed tray group	C	-	C	-	-	-	C	-	F	D	-		
		0.1		0.1				0.1		0.5	0.5			
4	Guide rod	C	-	C	-	-	-	C	F	-	D	-		
		0.1		0.1				0.1	0.1		0.1			
5	Driving spring	C	-	C	-	-	-	C	O	-	-	-		
		0.1		0.1				0.1						
6	Back plate assembly w/ solenoid	C	-	C	F	-	-	C	-	F	D	-		
		0.1		0.1	0.7			0.1		0.5	3.0			
7	Breechblock assembly	C	-	C	-	-	-	C	C	F	D	-		
		0.1		0.1				0.1	0.1	0.2	0.4			
8	Barrel extension assembly	C	-	C	-	-	-	C	C	F	D	-		
		0.3		0.1				0.2	0.2	0.5	6.0			
9	Charger assembly	C	-	C	-	-	-	C	-	F	D	-		
		0.1		0.1				0.2		0.2	2.0			
10	Receiver assembly	C	-	C	-	-	-	-	-	O	D	-		
		0.2		0.1						0.2	6.0			



## APPENDIX C

## ORGANIZATIONAL, DIRECT SUPPORT, AND GENERAL SUPPORT

## MAINTENANCE REPAIR PARTS AND

## SPECIAL TOOLS LIST

## (INCLUDING DEPOT MAINTENANCE REPAIR PARTS AND SPECIAL TOOLS)

## Section I. INTRODUCTION

**C-1. Scope**

This appendix lists repair parts, special tools, and test and support equipment required for the performance of organizational, direct support, general support and depot maintenance of the Machine Guns, 7.62-MM, M73, M73A1 and M219.

**C-2. General**

This Repair Parts and Special Tools List is divided into the following sections:

a. *Repair Parts List—Section II.* A list of repair parts authorized at the organizational level for the performance of maintenance. It also includes parts which must be removed for replacement of the authorized parts. Parts lists are composed of functional groups in ascending numerical sequence, with the parts in each group listed in figure and item number sequence.

b. *Special Tools List—Section III.* A list of special tools, test and support equipment authorized for the performance of maintenance at the organizational level.

c. *Repair Parts List—Section IV.* A list of repair parts authorized at the direct support, general support, and depot levels for the performance of maintenance. The list also includes parts which must be removed for the replacement of the authorized parts. Parts lists are composed of functional groups in ascending numerical sequence, with parts in each group listed in figure and item number sequence.

d. *Special Tools List—Section V.* A list of special tools, test and support equipment authorized for the performance of maintenance at the direct support, general support, and depot levels.

e. *Federal Stock Number and Reference Number Index—Section VI.* A list, in ascending numerical sequence, of all Federal stock numbers

appearing in the listings, followed by a list, in alphabetic sequence, of all reference numbers appearing in the listings. Federal stock number and reference numbers are cross-referenced to each illustration figure and item number appearance.

**C-3. Explanation of Columns**

The following provides an explanation of columns found in the tabular listings.

a. *Source, Maintenance, and Recoverability Codes (SMR).*

(1) *Source Code.* Indicates the source for the listed items. Source codes are:

<i>Code</i>	<i>Explanation</i>
P	Repair parts, special tools, and test equipment supplied from the GSA / DSA, or Army supply system, and authorized for use at indicated maintenance categories.
P2	Repair parts, special tools, and test equipment which are procured and stocked for insurance purposes because the combat or military essentiality of the end item dictates that a minimum quantity be available in the supply system.
P9	Assigned to items which are NSA design controlled: unique repair parts, special tools, test, measuring and diagnostic equipment, which are stocked and supplied by the Army COMSEC Logistic System and which are not subject to the provisions of AR 380-41.
P10	Assigned to items which are NSA design controlled: special tools, test, measuring and diagnostic equipment for COMSEC support which are accountable under the provisions of AR 380-41, and which are stocked and supplied by the Army COMSEC Logistic System.
M	Repair parts, special tools and test equipment which are not procured or stocked as such in the supply system but are to be manufactured at indicated maintenance levels.
A	Assemblies which are not procured or stocked as such but are made up of two or more units. Such component units carry individual stock numbers and descriptions, are procured and stocked separately, and can be assembled to form the required assembly at indicated maintenance categories.

<i>Code</i>	<i>Explanation</i>
X	Parts and assemblies that are not procured or stocked because the failure rate is normally below that of the applicable end item or component. The failure of such part or assembly should result in retirement of the end item from the supply system.
X1	Repair parts which are not procured or stocked. The requirement for such items will be filled by the next higher assembly or component.
X2	Repair parts, special tools and test equipment which are not stocked and have no foreseen mortality. The indicated maintenance category requiring such repair parts will attempt to obtain the parts through cannibalization or salvage. The item may be requisitioned, with exception data, from the end item manager for immediate use.
G	Major assemblies that are procured with PEMA funds for initial issue only as exchange assemblies at DS and GS level. These assemblies will not be stocked above DS and GS level or returned to depot supply level.

**NOTE**

Cannibalization or salvage may be used as a source of supply for any items source coded above except those coded X1 and aircraft support items as restricted by AR 700-42.

(2) *Maintenance Code*. Indicates the lowest category of maintenance authorized to install the repair part and / or use the special tool or test equipment for each application. Capabilities of higher maintenance categories are considered equal or better. Maintenance codes are:

<i>Code</i>	<i>Explanation</i>
C	Crew / operator
O	Organizational maintenance
F	Direct support maintenance
H	General support maintenance
D	Depot maintenance

(3) *Recoverability Code*. Indicates whether unserviceable items should be returned for recovery or salvage. Items not coded are nonrecoverable. Recoverability codes are:

<i>Code</i>	<i>Explanation</i>
R	Repair parts (assemblies and components), special tools and test equipment which are considered economically repairable at direct and general support maintenance levels. When the item is no longer economically repairable, it is normally disposed of at the GS level. When supply considerations dictate, some of these repair parts may be listed for automatic return to supply for depot level repair as set forth in AR 710-1. When so listed, they will be replaced by supply on an exchange basis.
S	Repair parts, special tools and test equipment, and assemblies which are economically repairable at DS and GS activities and which normally are furnished by supply on an exchange basis. When items are determined by a GSU to be uneconomically repairable, they will be evacuated to a depot for evaluation and analysis before final disposition.

<i>Code</i>	<i>Explanation</i>
T	High dollar value recoverable repair parts, special tools and test equipment which are subject to special handling and are issued on an exchange basis. Such items will be repaired or overhauled at depot maintenance activities only. No repair may be accomplished at lower levels.
U	Repair parts, special tools and test equipment specifically selected for salvage by reclamation units because of precious metal content, critical materials, high dollar value, or reusable casings or castings.

b. *Federal Stock Number*. Indicates the Federal stock number assigned to the item and will be used for requisitioning purposes.

c. *Description*. Indicates the Federal item name and a minimum description required to identify the item. The last line indicates the reference number followed by the applicable Federal Supply' Code for Manufacturer (FSCM) in parentheses. The FSCM is used as an element in item identification to designate manufacturer or distributor or Government agency, etc., and is identified in SB 708-42. Items that are included in kits and sets are listed below the name of the kit or set with quantity of each item in the kit or set indicated in front of the item name.

d. *Unit of Measure (U/M)*. Indicates the standard or basic quantity by which the listed item is used in performing the actual maintenance function. This measure is expressed by a two-character alphabetical abbreviation, e.g., ea, in, pr, etc., and is the basis used to indicate quantities and allowances in subsequent columns. When the unit of measure differs from the unit of issue, the lowest unit of issue that will satisfy the required units of measure will be requisitioned.

e. *Quantity Incorporated in Unit*. Indicates the quantity of the item used in the breakout shown on the illustration figure, which is prepared for a functional group, subfunctional group, or an assembly. A "V" appearing in this column in lieu of a quantity indicates that no specific quantity is applicable, e.g., shims, spacers, etc.

f. *15-Day Organizational Maintenance Allowances*.

(1) The allowance columns are divided into four subcolumns. Items authorized for use are identified with an asterisk in the allowance column opposite the first appearance of each item. Subsequent appearances have the letters "REF" in the allowance columns.

(2) Subsequent changes to allowance lists will be accomplished in accordance with AR 710-2. In addition, the major commands will be authorized to approve reductions in stockage allowances (range and quantity). If additional items are considered

necessary, recommendation should be forwarded to, Commanding General, U. S. Army Weapons Command, ATTN: AMSWE-MAP, Rock Island, Illinois 61201, for exception or revision to the allowance list.

g. *30-Day DS/GS Maintenance Allowances.*

Note

Allowances in GS Column are for GS Maintenance only.

The allowance columns are divided into three subcolumns. Items authorized for use as required but not for initial stockage are identified with an asterisk in the allowance column opposite the first appearance of each item. Subsequent appearances of the same item will have the letters "REF" in the applicable allowance columns.

h. *1-Year Allowances Per 100 Equipments/Contingency Planning Purposes.* This column indicates opposite the first appearance of each item the authorization for distribution and contingency planning purposes. The range of items indicates the authorization of all items required to provide for adequate support of 100 equipments for one year. Subsequent appearances of the same item will have the letters "REF" in this column.

i. *Depot Maintenance Allowance per 100 Equipments.* This column indicates opposite the first appearance of each item the authorization for depot maintenance of 100 equipments. Items authorized for use are identified with an asterisk. Subsequent appearances of the same item will have the letters "REF" in this column.

j. *Illustration.* This column is divided as follows:

(1) *Figure Number.* Indicates the figure number of the illustration on which the item is shown.

(2) *Item Number.* Indicates the callout number used to reference the item on the illustration.

**C-4. Special Information.**

a. Usable on codes are included in Column 3. Uncoded items are applicable to all models. Identifications of the usable on codes used in this publication are:

<i>Code</i>	<i>Used on</i>
A	M73
B	M73A1 and M219
C	M219

b. Bulk materials required to manufacture items are listed in the Bulk Materials Group of this manual.

c. Detailed assembly instructions for items source coded "A" are found in the maintenance portion of this manual. Assembly components are listed immediately following the item to be assembled.

d. Action change codes indicated in the left-hand margin of the listing page denote the following:

- N—Indicates an added item.
- C—Indicates a change in data.
- R—Indicates a change in FSN only.

**C-5. How to Locate Repair Parts**

a. When Federal stock number or reference number is unknown:

(1) *First.* Using the table of contents determine the functional group within which the repair part belongs. This is necessary since illustrations are prepared for functional groups, and listings are divided into the same groups.

(2) *Second.* Find the illustration covering the functional group to which the repair part belongs.

(3) *Third.* Identify the repair part on the illustration and note the illustration figure and item number of the repair part.

(4) *Fourth.* Using the Repair Parts Listing, find the functional group to which the repair part belongs and locate the illustration figure and item number noted on the illustration.

b. When Federal stock number or reference number is known:

(1) *First.* Using the Index of Federal Stock Numbers and Reference Numbers find the pertinent Federal stock number or reference number. This index is in ascending FSN sequence followed by a list of reference numbers in ascending alphameric sequence, cross-referenced to the illustration figure number and item number.

(2) *Second.* Using the Repair Parts Listing, find the functional group of the repair part and the illustration figure number and item number referenced in the Index of Federal Stock Numbers and Reference Numbers.

**C-6. Abbreviations**

<i>Abbreviations</i>	<i>Explanation</i>
ad	adjust
anld	annealed
blk-oxide fin	black oxide finish
cap	capacity
cd-pltd	cadmium plated
ck-hd	countersunk head
cre s	corrosion-resistant steel
fl-ck-hd	flat countersunk head
h	light
NF	National fine (thread)
pt	point
UNF	Unified fine thread
w/mtg	with mounting

## Section II. REPAIR PARTS LIST

(1) SOURCE MAINT AND RECOV CODE			(2) FEDERAL STOCK NO.	(3) DESCRIPTION  Reference Number & Mfr Code  Usable on Code	(4) UNIT OF MEAS	(5) QTY INC IN UNIT	(6) 15-DAY ORGANIZATIONAL MAINTENANCE ALW				(7) ILLUSTRATION	
(a) Source	(b) Maint	(c) Recov					(a) 1-5	(b) 6-20	(c) 21-50	(d) 51-100	(a) Figure No.	(b) Item No.
				REPAIR PARTS								
C	P	C	1005-689-9942	MAJOR GROUPS AND ASSEMBLIES LOCK, BARREL BEARING: 7793523-2 (19204)	EA	1	*	*	*	*	C-1	2
	P	C	1005-972-0196	BARREL ASSEMBLY: 7792874 (19204)	EA	1	*	*	*	*	C-1	4
C	P	C	1005-856-7995	SPRING, HELICAL COMPRESSION: 9.100 FREE LG, DRIVING 7792838 (19204)	EA	2	*	*	*	*	C-1	9
	P	C	1005-921-6317	BREECHBLOCK ASSEMBLY: 11013422 (19204)	EA	1	*	*	*	*	C-1	12
	P	C	1005-937-8256	EXTENSION ASSEMBLY, BARREL: 11013360 (19204)	EA	1	*	*	*	*	C-1	13
	P	C	1005-832-9612	EXTENSION ASSEMBLY, BARREL: 11013432 (19204)	EA	1	*	*	*	*	C-1	13
	P	C	5365-209-6975	RING, RETAINING: EXT. S, PHOS-CTD, 0.302 ID, 3/8 SHAFT DIA MS 16633-3037 (96906)	EA	1	*	*	*	*	C-1	15
	P	C	1005-832-9613	STUD, MOUNTING CHARGER: 11013434 (19204)	EA	1	*	*	*	*	C-1	17
	P	O	1005-690-0315	COVER ASSEMBLY TRACK ASSEMBLY, SLIDE: 7793610 (19204)	EA	1	*	*	*	*	C-3	10
C	P	O	1005-690-0322	FEED TRAY GROUP TRAY ASSEMBLY, FEED: 7793641 (19204)	EA	1	*	*	*	*	C-4	6
C	P	O	1005-832-9615	TRAY, FEED: 11013441 (19204)	EA	1	*	*	*	*	C-4	6
	P	C	5365-209-6975	RECEIVER ASSEMBLY RING, RETAINING: EXT, S, PHOS-CTD, 0.302 ID, 3/8 SHAFT DIA MS 16633-3037 (96906)	EA	2	REF	REF	REF	REF	C-12	4
	P	C	5365-209-6975	RING, RETAINING: EXT, S, PHOS-CTD, 0.302 ID, 3/8 SHAFT DIA MS 16633-3037 (96906)	EA	1	REF	REF	REF	REF	C-12 C-13	4 4
	P	O	1005-690-0568	SPRING, HELICAL, COMPRESSION: DISCONNECTOR 7793506 (19204)	EA	2	*	*	*	*	C-12 C-13	9 9

**Section III. SPECIAL TOOLS LIST**

(1) SOURCE MAINT AND RECOV CODE			(2) FEDERAL STOCK No.	(3) DESCRIPTION  Reference Number & Mfr Code                      Usable on Code	(4) UNIT OF MEAS	(5) QTY INC IN UNIT	(6) 15-DAY ORGANIZATIONAL MAINTENANCE ALW				(7) ILLUSTRATION	
(a)	(b)	(c)					(d)	(a)	(b)			
Source	Maint	Recov								1-5	6-20	21-50
C	P	O	1005-288-3565	TOOLS AND EQUIPMENT AUTHORIZED FOR UNIT REPLACEMENT SWAB, SMALL ARMS CLEANING: COTTON, 2-1/2 SQ (1000 IN PG) 5019316 (19204)	PG		*	1	2	4		
R	P	C	1005-350-4100	BRUSH, CLEANING, SMALL ARMS: RECEIVER 8448466 (19204)	EA		*	1	2	3	C-14	11
C	P	C	1005-550-6573	CASE, SMALL ARMS CLEANING ROD: 5506573 (19204)	EA		*	*	1	1	C-14	2
C	P	C	1005-556-4174	BRUSH, CLEANING, SMALL ARMS: BORE 5564174 (19204)	EA		1	3	6	11	C-14	14
C	P	C	1005-689-9942	LOCK, BARREL BEARING: (FOR M60A1E2 TANKS ONLY) 7793523-2 (19204)	EA		*	*	*	1	C-1	2
C	P	C	1005-690-3115	BRUSH, CLEANING, SMALL ARMS: CHAMBER 7790452 (19204)	EA		*	1	2	3	C-14	10
C	P	C	1005-694-1662	BUFFER, CLEANING ROD: 7268275 (19204)	EA		*	*	1	2	C-14	4
C	P	C	1005-714-5250	BOX, SPARE PARTS: 7790683 (19204)	EA		*	*	1	1	C-14	12
C	P	C	1005-726-6109	ROD SECTION, CLEANING, SMALL ARMS: 7266109 (19204)	EA		*	1	2	4	C-14	5
C	P	C	1005-726-6110	SWAB HOLDER SECTION, SMALL ARMS CLEANING ROD: 7266110 (19204)	EA		*	*	1	2	C-14	6
C	P	C	1005-793-6761	HANDLE ASSEMBLY: CLEANING ROD 7266115 (19204)	EA		*	*	1	1	C-14	3
C	P	C	1005-869-8817	SUPPRESSOR, FLASH: (M60A1 AND M60A1E2 TANKS) 11013376 (19204)	EA		*	1	1	2	C-14	9
C	P	C	1005-922-9777	FLASH HIDER: S, PHOS-CTD, 1.030 BORE DIA, 5.280 O/A LG, W/MTG FACILITIES 11013420 (19204)	EA		*	1	1	2	C-14	13
C	P	C	1005-933-8070	EXTENSION, JACKET, BARREL: (FOR M60A1E2 TANK ONLY) 11013438 (19204)	EA		*	1	1	2	C-14	15
C	P	C	4933-652-9950	EXTRACTOR, RUPTURED CARTRIDGE CASE: 7790352 (19204)	EA		*	*	1	1	C-14	7
C	P	C	4933-733-4759	COMBINATION TOOL: 7791083 (19204)	EA		*	*	1	1	C-14	8
C	P	C	5120-242-5966	PUNCH, DRIVE, PIN: STRAIGHT, 3/4 IN LG, 1/8 IN DIA PT GGG-P-831 (81348)	EA		*	*	*	*	C-14	17

TM 9-1005-233-24

## Section III. SPECIAL TOOLS LIST — Continued

(1) SOURCE MAINT AND RECOV CODE			(2) FEDERAL STOCK NO.	(3) DESCRIPTION  Reference Number & Mfr Code                      Usable on Code		(4) UNIT OF MEAS	(5) QTY INC IN UNIT	(6) 15-DAY ORGANIZATIONAL MAINTENANCE ALW				(7) ILLUSTRATION	
(a) Source	(b) Maint	(c) Recov						(a) 1-5	(b) 6-20	(c) 21-50	(d) 51-100	(a) Figure No.	(b) Item No.
C	P	C	5120-264-3793	WRENCH: AUTO, ADJ 15 IN LG O/A, 0 TO 5/8 MIN JAW OPENING CAP		EA		*	*	1	1	C-14	1
C	P	C	9150-889-3522	GGG-W-631A TYPE E2 (81348) LUBRICATING OIL, SEMIFLUID: (LSA) 402 BOTTLE 8436793 (19207)		OZ		1	2	4	6	C-14	16

**Section IV. REPAIR PARTS LIST**

(1) SMR Code	(2) Federal Stock Number	(3) Description		(4) Unit of meas	(5) Qty inc. in unit	(6) 30-day DS maint allowance			(7) 30-day GS maint allowance			(8) 4-yr alw per 100 equip cnt- gy	(9) Depot maint w per 100 equip	(10) Illustration	
						(a)	(b)	(c)	(a)	(b)	(c)			(a) Figure No.	(b) Item No.
						1-20	21-50	51-100	1-20	21-50	1-100				
		Reference Number & Mfr. Code	Usable On Code												
		REPAIR PARTS													
		MAJOR GROUPS AND ASSEMBLIES:													
C A F	.....	JACKET ASSEMBLY WITH BEARING GROUP:		EA	1		..	..	..	..	..	..	..	C-1	1
C P C	1005-689-9942	LOCK, BARREL BEARING: 7793523-2 (19204)		EA	1	*	*	*	*	*	*	*	*	C-1	2
C A F	.....	JACKET ASSEMBLY WITH BEARING:		EA	1	..	..	..	..	..	..	..	..	C-1	3
P C	1005-972-0196	BARREL ASSEMBLY: 11013401 (19204)		EA	1	*	*	*	*	*	*	*	*	C-1	4
C A F	.....	COVER ASSEMBLY: 7792874 (19204)		EA	1	..	..	..	..	..	..	..	..	C-1	5
C A F	.....	FEED TRAY GROUP:		EA	1	..	..	..	..	..	..	..	..	C-1	6
N A F	.....	FEED TRAY GROUP:		EA	1	..	..	..	..	..	..	..	..	C-1	6
C A F	.....	BACK PLATE ASSEMBLY, DRIVING SPRINGS, AND GUIDE ROD GROUP:		EA	1	..	..	..	..	..	..	..	..	C-1	7
P F	1005-690-0306	ROD ASSEMBLY, DRIVE SPRING GUIDE: 7793583 (19204)		EA	2	*	*	*	*	*	*	*	*	C-1	8
C P C	1005-856-7995	SPRING, HELICAL, COMPRESSION: 9.100 FREE LG, DRIVING 7792838 (19204)		EA	2	*	*	*	*	*	*	*	*	C-1	9
C A F	.....	PLATE ASSEMBLY: BACK, W/SOLENOID 11013437 (19204)		EA	1	..	..	..	..	..	..	..	..	C-1	10
C A F	.....	BARREL EXTENSION GROUP:		EA	1	..	..	..	..	..	..	..	..	C-1	11
P C R	1005-921-6317	BREECHBLOCK ASSEMBLY: 11013422 (19204)		EA	1	*	*	*	*	*	*	*	..	C-1	12
C P C R	1005-937-8256	EXTENSION ASSEMBLY, BARREL: 11013360 (19204)		EA	1	*	*	*	*	*	*	*	..	C-1	13
C P C R	1005-832-9612	EXTENSION ASSEMBLY, BARREL: 11013432 (19204)		EA	1	*	*	*	*	*	*	*	..	C-1	13
C A F	.....	CHARGER GROUP:		EA	1	..	..	..	..	..	..	..	..	C-1	14
P C	5365-209-6975	RING, RETAINING: EXT. S, PHOS-CTD, 0.302 ID, 3/8 SHAFT DIA MS16633-3037 (96906)		EA	1	*	*	*	*	*	*	*	*	C-1	15
C A F	.....	CHARGER ASSEMBLY: 7793684 (19204)		EA	1	..	..	..	..	..	..	..	..	C-1	16
P C	1005-832-9613	STUD, MOUNTING CHARGER: 11013434 (19204)		EA	1	*	*	*	*	*	*	*	*	C-1	17
C XIF	.....	RECEIVER ASSEMBLY: 7793647 (19204)		EA	1	..	..	..	..	..	..	..	..	C-1	18

TM 9-1005-233-24

Section IV. REPAIR PARTS LIST — Continued

(1) SMR Code	(2) Federal Stock Number	(3) Description		(4) Unit of meas	(5) Qty inc. in unit	(6) 30-day DS maint allowance			(7) 30-day GS maint allowance			(8) 1-yr alw per 100 equip cnt- gcy	(9) Depot maint alw per 100 equip	(10) Illustration	
						(a)	(b)	(c)	(a)	(b)	(c)			(a)	(b)
						1-20	21-50	51-100	1-20	21-50	51-100			Figure No.	No.
C X	.....	RECEIVER ASSEMBLY: 11013373 (19204)	B	EA	1	..	..	..	..	..	..	..	..	C-1	18
C P F	5315-810-5133	JACKET ASSEMBLY W/ BEARING PIN, SPRING: S, PHOS-CTD, 3/16 DIA, 3/4 LG MS39086-204 (96906)		EA	1	*	*	*	*	*	*	*	*	C-2	1
P F	1005-859-7934	LOCATOR, BARREL: 7792854 (19204)		EA	1	*	*	*	*	*	*	*	*	C-2	2
P F	1005-689-9939	BEARING, BARREL: 11013349 (19204)		EA	1	*	*	*	*	*	*	*	*	C-2	3
P F	1005-689-9941	LOCK BARREL BEARING: 7793523-1 (19204)		EA	1	*	*	*	*	*	*	*	*	C-2	4
P F R	1005-924-1773	JACKET, BARREL: 11013400 (19204)		EA	1	*	*	*	*	*	*	*	*	C-2	5
P F	1005-690-0309	COVER ASSEMBLY CAM, FEED : 7793600 (19204)		EA	1	*	*	*	*	*	*	*	*	C-3	1
A F	.....	FEED SUPPORT ASSEMBLY: 7793613 (19204)		EA	1	..	..	..	..	..	..	..	..	C-3	2
C P F	5315-812-1007	PIN, SPRING : SPIRAL TYPE, HV-DUTY, S, PHOS-CTD 1/8 x 9/16 MS39086-91 (96906)		EA	2	*	*	*	*	*	*	*	*	C-3	3
P F	1005-690-0316	DEPRESSOR, CARTRIDGE: FEED SUPPORT ASSY 7793617 (19205)		EA	1	*	*	*	*	*	*	*	*	C-3	4
P F	1005-690-0605	STRIPPER, CARTRIDGE: 7793571 (19204)		EA	1	*	*	*	*	*	*	*	*	C-3	5
C P F	1005-690-0570	SPRING, HELICAL, COMPRESSION: DEPRESSOR AND STRIPPER 7793508 (19204)		EA	2	*	*	*	*	*	*	*	*	C-3	6
C P F	5315-812-9525	PIN, SPRING: S, PHOS-CTD, 3/32 DIA, 3/4 LG MS39086-83 (96906)		EA	2	*	*	*	*	*	*	*	*	C-3	7
P F	1005-690-0592	RETAINER, SPRING, DEPRESSOR: 7793544 (19204)		EA	2	*	*	*	*	*	*	*	*	C-3	8
P F	1005-690-0619	SUPPORT, FEED: 7793599 (19204)		EA	1	*	*	*	*	*	*	*	*	C-3	9
P O R	1005-690-0315	TRACK ASSEMBLY, SLIDE: 7793610 (19204)		EA	1	*	*	*	*	*	*	*	*	C-3	10
P F	5315-690-0565	PIN, SPRING: PAWL RETAINING 7793501 (19204)		EA	2	*	*	*	*	*	*	*	*	C-3	11



Section IV. REPAIR PARTS LIST — Continued

(1) SMR Code	(2) Federal Stock Number	(3) Description  Reference Number & Mfr. Code Usable On Code		(4) Unit of meas	(5) Qty inc. in unit	(6) 30-day DS maint allowance			(7) 30-day GS maint allowance			(8) 1-yr alw per 100 equip cnt- gcy	(9) Depot maint alw per 100 equip	(10) Illustration	
						(a) 1-20	(b) 21-50	(c) 51-100	(a) 1-20	(b) 21-50	(c) 51-100			(a) Figure No.	(b) Item No.
P F	1005-690-0626	PAWL, RETAINING: 7793618 (19204)		EA	2	*	*	*	*	*	*	*	*	C-3	12
P F	1005-690-0562	SPRING, HELICAL, COMPRESSION: BELT RETAINING PAWL 7793496 (19204)		EA	2	*	*	*	*	*	*	*	*	C-3	13
XIF	.....	TRACK, FEED SLIDE: 7793595 (19204)		EA	1	..	..	..	..	..	..	..	..	C-3	14
C A F	.....	SLIDE ASSEMBLY, FEED: 7793579 (19204)		EA	1	..	..	..	..	..	..	..	..	C-3	15
P F	5365-282-2426	RING, RETAINING: S, PHOS-CTD, EXT STYLE E, 0.188 SHAFT DIA MS 16633-3018 (96906)		EA	1	*	*	*	*	*	*	*	*	C-3	16
P F	1005-690-0549	ROLLER, FEED SLIDE: S, 0.190 W, 0.251 ID, 0.374 OD 7793478 (19204)		EA	1	*	*	*	*	*	*	*	*	C-3	17
P F	5315-690-0544	PIN, SPRING: FEED PAWL PIVOT, S, 11/16 LG OD 7793470 (19204)		EA	1	*	*	*	*	*	*	*	*	C-3	18
C P F	1005-044-1896	PAWL: FEED, 7.62-MM 7792898 (19204)		EA	1	*	*	*	*	*	*	*	*	C-3	19
P F	5360-690-0546	SPRING, HELICAL, TORSION: FEED PAWL 7793473 (19204)		EA	1	*	*	*	*	*	*	*	*	C-3	20
P F	1005-690-0294	SLIDE, FEED: FEED SLIDE ASSEMBLY 7793542 (19204)		EA	1	*	*	*	*	*	*	*	*	C-3	21
P F	1005-690-0618	RETAINER, FEED SUPPORT: 7793598 (19204)		EA	1	*	*	*	*	*	*	*	*	C-3	22
P F	1005-690-0550	PLUNGER, RETAINERS: S, 0.249 OD, 0.173 ID, 0.380 H O / A 7793479 (19204)		EA	1	*	*	*	*	*	*	*	*	C-3	23
P F	1005-690-0569	SPRING, HELICAL, COMPRESSION: FIRING PIN 7793507 (19204)		EA	1	*	*	*	*	*	*	*	*	C-3	24
P F R	1005-690-0323	COVER AND TRACK ASSEMBLY: 7793643 (19204)		EA	1	*	*	*	*	*	*	*	*	C-3	25
P F	1005-950-0790	FEED TRAY GROUP STOP ASSEMBLY, CARTRIDGE: 11013395 (19204)		EA	1	*	*	*	*	*	*	*	*	C-4	1
P F	5315-690-0572	PIN, SPRING: ROUND STOP PLUNGER RETAINING 7793512 (19204)		EA	1	*	*	*	*	*	*	*	*	C-4	2
P F	1005-690-0569	SPRING, HELICAL, COMPRESSION: FIRING PIN 7793507 (19204)		EA	1	REF	REF	REF	REF	REF	REF	REF	REF	C-4	3

TM 9-1005-233-24

## Section IV. REPAIR PARTS LIST — Continued

(1) SMR Code	(2) Federal Stock Number	(3) Description  Reference Number & Mfr. Code                      Usable On Code		(4) Unit of meas	(5) Qty inc. in unit	(6) 30-day DS maint allowance			(7) 30-day GS maint allowance			(8) 1-yr alw per 100 equip cnt - gcy	(9) Depot maint alw per 100 equip	(10) Illustration	
						(a)	(b)	(c)	(a)	(b)	(c)			(a)	(b)
						1-20	21-50	51-100	1-20	21-50	51-100			Figure No.	Item No.
P F	1005-690-0591	PLUNGER, CARTRIDGE STOP: 7793543 (19204)		EA	1	*	*	*	*	*	*	*	*	C-4	4
XIF	.....	STOP, CARTRIDGE: 11013394 (19204)		EA	1	..	..	..	..	..	..	..	..	C-4	5
C P O	1005-690-0322	TRAY ASSEMBLY, FEED: 7793641 (19204)		EA	1	*	*	*	*	*	*	*	*	C-4	6
C P O	1005-832-9615	TRAY, FEED: 11013441 (19204)		EA	1	*	*	*	*	*	*	*	*	C-4	6
P F	5315-999-4687	BACK PLATE ASSEMBLY W/SOLENOID PIN, TRIGGER PIVOT: BACK PLATE ASSY W/ SOLENOID 11013398 (19204)		EA	1	*	*	*	*	*	*	*	*	C-5	1
P F	1005-990-9285	TRIGGER: SOLENOID 11013424 (19204)		EA	1	*	*	*	*	*	*	*	*	C-5	2
P F	1005-875-9768	SPRING, HELICAL, COMPRESSION: TRIGGER 7792871 (19204)		EA	2	*	*	*	*	*	*	*	*	C-5	3
P F	1005-999-4689	SAFETY, TRIGGER: BACK PLATE ASSY W/ SOLENOID 11013418 (19204)		EA	1	*	*	*	*	*	*	*	*	C-5	4
C P F	1005-990-9283	SPRING, TRIGGER SAFETY: 11013423 (19204)		EA	1	*	*	*	*	*	*	*	*	C-5	5
P F	5315-690-0579	PIN, STRAIGHT, HEADLESS: SOLENOID LEVER 7793519 (19204)		EA	1	*	*	*	*	*	*	*	*	C-5	6
P F	1005-999-4688	LEVER, SOLENOID: BACK PLATE ASSY W/SOLENOID 11013417 (19204)		EA	1	*	*	*	*	*	*	*	*	C-5	7
C P F	5310-971-7989	NUT, PLAIN, HEXAGON: S, CD-PLTD, 5/16 - 28UNF- 2B, 3/16 W ACROSS FLATS, 5/32 THK MS 35691-5 (96906)		EA	1	*	*	*	*	*	*	*	*	C-5	8
R P F	5310-274-8715	WASHER, LOCK: SPLIT, LT, S, PHOS-CTD, 1/4 SCREW SIZE MS 35338-63 (96906)		EA	2	*	*	*	*	*	*	*	*	C-5	9
P F	1005-966-9315	SHIELD, NUT: 7792919 (19204)		EA	1	*	*	*	*	*	*	*	*	C-5	10
P F	1005-788-9140	SOLENOID, FIRING: BACK PLATE ASSY 7793702 (19204)		EA	1	*	*	*	*	*	*	*	*	C-5	11
C P F	1005-930-4803	SEAR, TRIGGER: 11013367 (19204)		EA	1	*	*	*	*	*	*	*	*	C-5	12

**Section IV. REPAIR PARTS LIST — Continued**

(1) SMR Code	(2) Federal Stock Number	(3) Description  Reference Number & Mfr. Code  Usable On Code		(4) Unit of meas	(5) Qty inc. in unit	(6) 30-day DS maint allowance			(7) 30-day GS maint allowance			(8) 1-yr alw per 100 quip cnt- gcy	(9) Depot maint alw per 100 equip	(10) Illustration	
						(a)	(b)	(c)	(a)	(b)	(c)			(a) Figure No.	(b) Item No.
						1-20	21-50	51-100	1-20	21-20	21-100				
P F	5315-990-9287	PIN, TRIGGER SAFETY :		EA	2	*	*	*	*	*	*	*	*	C-5	13
C P F R	1005-990-9286	PLATE, BACK: 11013427 (19204)		EA	1	*	*	*	*	*	*	*	*	C-5	14
C P F	5315-810-3703	BREECHBLOCK ASSEMBLY PIN, SPRING: S, PHOS-FIN, 0.078 NOM DIA X 1/2 IN LG. TUBULAR, COILED, HV-DUTY MS 39086-68 (96906)		EA	1	*	*	*	*	*	*	*	*	C-6	1
P F	1005-690-0601	PIN, FIRING: 7793561 (19204)		EA	1	*	*	*	*	*	*	*	*	C-6	2
P F	1005-690-0569	SPRING, HELICAL, COMPRESSION: FIRING PIN 7793507 (19204)		EA	1	REF	REF	REF	REF	REF	REF	REF	REF	C-6	3
P F	5315-814-3533	PIN, SPRING: DRIVING STUD AND BREECHBLOCK STUD MS 39086-58 (96906)		EA	1	*	*	*	*	*	*	*	*	C-6	4
C P F	1005-690-0599	SHAFT, ROLLER, BREECHBLOCK AND RAMMER: 7793559 (19204)		EA	1	*	*	*	*	*	*	*	*	C-6	5
P F	1005-690-0600	ROLLER, BREECHBLOCK AND RAMMER AC- TUATOR: 7793560 (19204)		EA	1	*	*	*	*	*	*	*	*	C-6	6
X I F	.....	BREECHBLOCK: 11013421 (19204)		EA	1	..	..	..	..	..	..	..	..	C-6	7
P F	5315-690-0632	BARREL EXTENSION ASSEMBLY PIN, GROOVED, HEADLESS: LEVER PIVOT 7793663 (19204)		EA	1	*	*	*	*	*	*	*	*	C-7	1
C P F	1005-986-0263	LINK ASSEMBLY, CASE CARRIER: 7792890(19204)		EA	1	*	*	*	*	*	*	*	*	C-7	2
C P F	5315-812-1007	PIN SPRING: SPIRAL TYPE, HV-DUTY, S, PHOS-CTD 1/8 X 9-16 MS39086-91 (96906)		EA	1	REF	REF	REF	REF	REF	REF	REF	REF	C-7	3
C A F	.....	CARRIER ASSEMBLY: CASE 11013378(19204)		EA	1	..	..	..	..	..	..	..	..	C-7	4
C A F	.....	LEVER ASSEMBLY: 7793612(19204)		EA	1	..	..	..	..	..	..	..	..	C-7	5
C A F	.....	LEVER ASSEMBLY: 11013446(19204)		EA	1	..	..	..	..	..	..	..	..	C-7	5
C A F	.....	RAMMER ASSEMBLY: 7793611(19204)		EA	1	..	..	..	..	..	..	..	..	C-7	6

TM 9-1005-233-24

## Section IV. REPAIR PARTS LIST — Continued

(1) SMR Code	(2) Federal Stock Number	(3) Description	(4) Unit of meas	(5) Qty inc. in unit	(6) 30-day DS maint allowance			(7) 30-day GS maint allowance			(8) 1-yr alw per 100 equip cnt- gcy	(9) Depot maint alw per 100 quip	(10) Illustration	
					(a)	(b)	(c)	(a)	(b)	(c)			(a) Figure No.	(b) Item No.
					1-20	21-50	51-100	1-20	21-50	51-100				
C A F	.....	RAMMER ASSEMBLY: 11013362 (19204) B	EA	1	..	..	..	..	..	..	..	..	C-7	6
P F	5312-812-1005	PIN, SPRING: S, PHOS-CTD 1/16 DIA, 5/16 LG MS 39086-52 (96906) A	EA	3	*	*	*	*	*	*	*	*	C-7	7
C P F	5315-874-2511	PIN, SPRING: COILED, HV-DUTY, 7/16 LG, 3/32 DIA MS 39086-79 (96906) B	EA	1	*	*	*	*	*	*	*	*	C-7	7
C A F	.....	HAMMER ASSEMBLY: 7792908 (19204)	EA	1	..	..	..	..	..	..	..	..	C-7	8
P F	5305-690-0602	SCREW, RETAINING, HAMMER: 7793567 (19204)	EA	1	*	*	*	*	*	*	*	*	C-7	9
P F	1005-690-0603	ROLLER, HAMMER COCKING : 7793568 (19204)	EA	1	*	*	*	*	*	*	*	*	C-7	10
P F	1005-990-9295	LINK, HAMMER: 7792899 (19204)	EA	1	*	*	*	*	*	*	*	*	C-7	11
P F	1005-990-9289	HAMMER, FIRING, SMALL ARMS: 7792878 (19204)	EA	1	*	*	*	*	*	*	*	*	C-7	12
P F	1005-690-0566	SPRING, HELICAL, COMPRESSION: HAMMER 7793504 (19204)	EA	1	*	*	*	*	*	*	*	*	C-7	13
P F	1005-990-9290	ROD, HAMMER SPRING GUIDE: 7792879 (19204)	EA	1	*	*	*	*	*	*	*	*	C-7	14
C P F	5315-807-4959	PIN, SPRING: S, PHOS-CTD, 3/32 X 3/8 LG MS 39086-78 (96906)	EA	1	*	*	*	*	*	*	*	*	C-7	15
P F	1005-690-0578	SPRING, HELICAL, COMPRESSION: RATE CONTROL PAWL 7793518 (19204)	EA	1	*	*	*	*	*	*	*	*	C-7	16
P F	1005-769-3094	PAWL, RATE CONTROL: 7793655 (19204)	EA	1	*	*	*	*	*	*	*	*	C-7	17
R P F	5305-690-0607	SCREW, MACHINE: HAMMER SEAR HOUSING 7793574 (19204)	EA	1	*	*	*	*	*	*	*	*	C-7	18
C A F	.....	SEAR GROUP											C-7	19
P F	1005-973-0251	SEAR, HAMMER: 7792894 (19204)	EA	1	*	*	*	*	*	*	*	*	C-7	20
P F	1005-690-0543	SPRING, HELICAL, COMPRESSION: HAMMER SEAR 7793468 (19204)	EA	1	*	*	*	*	*	*	*	*	C-7	21
P F	1005-999-0479	HOUSING, HAMMER SEAR: BARREL EXTENSION ASSY 11013402 (19204)	EA	1	*	*	*	*	*	*	*	*	C-7	22

**Section IV. REPAIR PARTS LIST—Continued**

(1) SMR Code	(2) Federal Stock Number	(3) Description	(4) Unit of meas	(5) Qty inc. in unit	(6) 30-day DS maint allowance			(7) 30-day GS maint allowance			(8) 1-yr alw per 100 equip cnt- gcy	(9) Depot maint alw per 100 equip	(10) Illustration	
					(a)	(b)	(c)	(a)	(b)	(c)			(a) Figure No.	(b) Item No.
					1-20	21-50	51-100	1-20	21-50	51-100				
P F	5315-814-3533	PIN, SPRING: DRIVING STUD AND BREECHBLOCK STUD MS 39086-58 (96906)	EA	2	REF	REF	REF	REF	REF	REF	REF	REF	C-7	23
P F	1005-937-8257	STUD, DRIVING: 11013403 (19204)	EA	2	*	*	*	*	*	*	*	*	C-7	24
P F	1005-690-0551	SPRING, HELICAL, COMPRESSION: DRIVING STUD 7793481 (19204)	EA	2	*	*	*	*	*	*	*	*	C-7	25
P F	1005-937-8255	EXTENSION, BARREL: 11013350 (19204)	EA	1	*	*	*	*	*	*	*	*	C-7	26
P F	5305-690-0552	CARRIER ASSEMBLY SETSCREW: S, NO. 6-40 NF-3A, 0.163 LG, 0.668 LG O/A 7793482 (19204)	EA	2	*	*	*	*	*	*	*	*	C-8	1
P F	1005-973-0245	GRIP, CASE CARRIER: RH 7792827 (19204)	EA	1	*	*	*	*	*	*	*	*	C-8	2
P F	1005-973-0246	GRIP, CASE CARRIER: LH 7792828(19204)	EA	1	*	*	*	*	*	*	*	*	C-8	3
C P F	1005-973-0249	SPRING, HELICAL, COMPRESSION: 0.54 FREE LG 7792892 (19204)	EA	1	*	*	*	*	*	*	*	*	C-8	4
C P F	1005-973-0250	SPRING, HELICAL, COMPRESSION: 0.53 FREE OD 7792893 (19204)	EA	1	*	*	*	*	*	*	*	*	C-8	5
P F	1005-912-1143	BODY, CASE CARRIER: CARRIER ASSY 11013377 (19204)	EA	1	*	*	*	*	*	*	*	*	C-8	6
C P F	5315 -824-7426	LEVER ASSEMBLY PIN, SPRING: HV-DUTY, S, PHOS-CTD, 1/16 NOM DIA. 070 MAX DIA, 3/8 LG MS 39086-53 (96906)	EA	1	*	*	*	*	*	*	*	*	C-9	1
C P F	1005-690-0599	SHAFT, ROLLER, BREECHBLOCK AND RAMMER: 7793559 (19204)	EA	1	REF	REF	REF	REF	REF	REF	REF	REF	C-9	2
P F	1005-690-0600	ROLLER, BREECH BLOCK AND RAMMER AC- TUATOR: 7793560 (19204)	EA	1	REF	REF	REF	REF	REF	REF	REF	REF	C-9	3
P F	1005-832-9618	ROLLER, RAMMER ACTUATOR: LEVER ASSY 11013447 (19204)	EA	1	*	*	*	*	*	*	*	*	C-9	3
P F	5315-812-1005	PIN, SPRING: S, PHOS-CTD, 1/16 DIA, 5/16 LG MS 39086-52 (96906)	EA	2	REF	REF	REF	REF	REF	REF	REF	REF	C-9	4
P F	1005-690-0597	SHAFT, ROLLER, LEVER ACTUATOR: 7793557 (19204)	EA	2	*	*	*	*	*	*	*	*	C-9	5

## Section IV. REPAIR PARTS LIST — Continued

(1) SMR Code	(2) Federal Stock Number	(3) Description  Reference Number & Mfr. Code  Usable On Code		(4) Unit of meas	(5) Qty inc. in unit	(6) 30-day DS maint allowance			(7) 30-day GS maint allowance			(8) 1-yr alw per 100 equip cnt- gcy	(9) Depot maint alw per 100 equip	(10) Illustration	
						(a)	(b)	(c)	(a)	(b)	(c)			(a)	(b)
						1-20	21-50	51-100	1-20	21-50	51-100			Figure No	Item No.
P F	1005-690-0598	ROLLER, LEVER ACTUATOR: 7793558 (19204)		EA	2	*	*	*	*	*	*	*	*	C-9	6
C P F	5315-807-4959	PIN, SPRING: S, PHOS-CTD, 3/32 X 3/8 LG MS 39086-78 (96906)		EA	1	REF	REF	REF	REF	REF	REF	REF	REF	C-9	7
P F	1005-769-3096	PLUNGER, LEVER PIVOT PIN: 7793662 (19204)		EA	1	*	*	*	*	*	*	*	*	C-9	8
C P F	5340-952-4705	SPRING, HELICAL, COMPRESSION: SPRING, PLUNGER LEVER PIVOT PIN MS 24.585-75 (96906)		EA	1	*	*	*	*	*	*	*	*	C-9	9
P F	1005-690-0620	LEVER, LEVER ASSEMBLY: 7793601 (19204)		EA	1	*	*	*	*	*	*	*	*	C-9	10
P F	1005-832-9617	LEVER, RAMMER: LEVER ASSY 11013445 (19204)		EA	1	*	*	*	*	*	*	*	*	C-9	10
P F	1005-690-0329	RAMMER ASSEMBLY EXTENSION, FIRING PIN: 7793660 (19204)		EA	1	*	*	*	*	*	*	*	*	C-10	1
P F	1005-690-0538	SPRING, HELICAL, COMPRESSION: FIRING PIN EXTENSION 7793403 (19204)		EA	1	*	*	*	*	*	*	*	*	C-10	2
N P F	1005-462-8634	RAMMER AND EXTRACTOR ASSEMBLY: 8448401 (19204)		EA	1	*	*	*	*	*	*	*	*	C-10	3
P F	5315-834-8712	PIN, SPRING: CRES, PHOS-FIN, TUBULAR COILED, HV-DUTY, 1/8 NOM DIA X 0.475 LG 7793748 (19204)		EA	1	*	*	*	*	*	*	*	*	C-10	4
P F	1005-690-0314	EXTRACTOR, RAMMER ASSEMBLY: 7793609 (19204)		EA	1	*	*	*	*	*	*	*	*	C-10	5
P F	1005-690-0536	SPRING, HELICAL, COMPRESSION: EXTRACTOR 7793461 (19204)		EA	1	*	*	*	*	*	*	*	*	C-10	6
P F	1005-690-0628	RAMMER, CARTRIDGE: 7793642 (19204)		EA	1	*	*	*	*	*	*	*	*	C-10	7
P F	1005-690-0297	CHARGER ASSEMBLY CONNECTOR, SLIDE, CHARGER: 7793551 (19204)		EA	1	*	*	*	*	*	*	*	*	C-11	1
P F	5305-804-1511	SCREW, SELF-LOCKING: TRUSS-HD, S, 1/4-28 THD, NYLON PELLET LOCKING FEATURE IN THD 7792870 (19204)		EA	2	*	*	*	*	*	*	*	*	C-11	2
P F	1005-690-0299	GUIDE, SPRING, CHARGER: 7793554 (19204)		EA	1	*	*	*	*	*	*	*	*	C-11	3

**Section IV. REPAIR PARTS LIST — Continued**

(1) SMR Code	(2) Federal Stock Number	(3) Description  Reference Number & Mfr. Code Usable On Code		(4) Unit of meas	(5) Qty inc. in unit	(6) 30-day DS maint allowance			(7) 30-day GS maint allowance			(8) 1-yr alw per 100 equip cnt- gcy	(9) Depot maint alw per 100 equip	(10) Illustration	
						(a)	(b)	(c)	(a)	(b)	(c)			(a)	(b)
						1-20	21-50	51-100	1-20	21-50	51-100			Figure No.	Item No.
P F	1005-690-0561	SPRING, HELICAL, COMPRESSION: CHARGER SLIDE 7793493 (19204)		EA	1	*	*	*	*	*	*	*	*	C-11	4
P F	1005-922-8058	ROLLER, CHARGER ASSEMBLY: 11013382 (19204)		EA	1	*	*	*	*	*	*	*	*	C-11	5
P F	1005-922-8059	SLIDE, CHARGER ASSEMBLY: 11013383 (19204)		EA	1	*	*	*	*	*	*	*	*	C-11	6
C P F	5315-812-0762	PIN, SPRING: S, PHOS-CTD, 1/16 DIA, 7/16 LG MS 39086-54 (96906)		EA	2	*	*	*	*	*	*	*	*	C-11	7
P F	1005-690-0595	RETAINER SLIDE CONNECTOR: 7793552 (19204)		EA	1	*	*	*	*	*	*	*	*	C-11	8
C P F	1005-690-0558	SPRING, HELICAL, COMPRESSION: 7793489 (19204)		EA	1	*	*	*	*	*	*	*	*	C-11	9
R P F	1005-240-5725	LINK, CONNECTING, ROLLER CHAIN: SPRING CLIP TYPE, 1/2 IN PITCH, 0.141 DIA 8448451 (19204)		EA	1	*	*	*	*	*	*	*	*	C-11	10
M F	.....	CHAIN: 40 LINKS 7793173-2 (19204)		LK	*	*	*	*	*	*	*	*	*	C-11	11
NOTE															
SEE BULK ISSUE ITEM															
P F	1005-690-0596	SUPPORT, SPRING, CHARGER: 7793555 (19204)		EA	1	*	*	*	*	*	*	*	*	C-11	12
P F	1005-715-7698	BRACKET, CHARGER, REAR: 7793681 (19204)		EA	1	*	*	*	*	*	*	*	*	C-11	13
C P F	5315-812-1007	PIN, SPRING : SPIRAL TYPE, HV-DUTY, S, PHOS-CTD, 1/8 X 9/16 MS 39086-91 (96906)		EA	1	REF	REF	REF	REF	REF	REF	REF	REF	C-11	14
P F	1005-796-7038	HANDLE: 7790951 (19204)		EA	1	*	*	*	*	*	*	*	*	C-11	15
P F	1005-715-7695	HOUSING, CHARGER ASSEMBLY: WELDING ASSY 7793677 (19204)		EA	1	*	*	*	*	*	*	*	*	C-11	16
P F	1005-715-7694	RECEIVER ASSEMBLY CAM, BREECHBLOCK: 7793614 (19204)		EA	1	*	*	*	*	*	*	*	*	C-12 C-13	1 1
P F	1005-715-7693	PLUNGER, CAM, BREECHBLOCK: 7793592 (19204)		EA	1	*	*	*	*	*	*	*	*	C-12 C-13	2 2
P F	1005-726-2853	SPRING, HELICAL, COMPRESSION: BREECHBLOCK CAM PLUNGER 7793525 (19204)		EA	1	*	*	*	*	*	*	*	*	C-12 C-13	3 3

Section IV. REPAIR PARTS LIST — Continued

74

(1) SMR Code	(2) Federal Stock Number	(3) Description  Reference Number & Mfr. Code      Usable On Code	(4) Unit of meas	(5) Qty inc. in unit	(6) 30-day DS maint allowance			(7) 30-day GS maint allowance			(8) 1-yr alw per 100 equip cnt- gcy	(9) Depot maint alw per 100 equip	(10) Illustration	
					(a) 1-20	(b) 21-50	(c) 51-100	(a) 1-20	(b) 21-50	(c) 51-100			(a) Figure No.	(b) Item No.
P c	5365-209-6975	RING, RETAINING: EXT, S, PHOS-CTD, 0.302 ID, 3/8 SHAFT DIA MS 16633-3037 (96906)      A	EA	2	REF	REF	REF	REF	REF	REF	REF	REF	C-12	4
P F	5365-209-6975	RING, RETAINING: EXT, S, PHOS-CTD, 0.302 ID, 3/8 SHAFT DIA MS 16633-3037 (96906)      B	EA	1	REF	REF	REF	REF	REF	REF	REF	REF	C-12 C-13	4 4
R P F	5315-990-9288	PIN, BUFFER PIVOT: RECEIVER ASSY 11013433 (19204)	EA	1	*	*	*	*	*	*	*	*	C-12 C-13	5 5
C P F	1005-904-9296	BUFFER ASSEMBLY: 11013397 (19204)      A	EA	1	*	*	*	*	*	*	*	*	C-12	6
P F	1005-832-9616	BUFFER, RECOIL MECHANISM: RECEIVER ASSY 11013442 (19204)      B	EA	1	*	*	*	*	*	*	*	*	C-12 C-13	6 6
P F	1005-973-0331	RING, PULL: DISCONNECTOR RECEIVER ASSY 11013436 (19204)	EA	2	*	*	*	*	*	*	*	*	C-12 C-13	7 7
P F	1005-921-6316	DISCONNECTOR, RECEIVER ASSEMBLY: 11013381 (19204)	EA	2	*	*	*	*	*	*	*	*	C-12 C-13	8 8
P O	1005-690-0568	SPRING, HELICAL, COMPRESSION: DISCONNECTOR 7793506 (19204)	EA	2	*	*	*	*	*	*	*	*	C-12 C-13	9 9
P F	5315-839-0901	PIN, SPRING: S, PHOS-CTD, 3/32 DIA, 9/16 LG, 00010 THK MTL MS 39086-81 (96906)	EA	1	*	*	*	*	*	*	*	*	C-12 C-13	10 10
P F	1005-690-0311	LEVER, BUFFER SUPPORT: RH RECEIVER ASSY 7793604 (19204)	EA	1	*	*	*	*	*	*	*	*	C-12 C-13	11 11
P F	1005-690-0308	LEVER, BUFFER SUPPORT: LH RECEIVER ASSY 7793593 (19204)	EA	1	*	*	*	*	*	*	*	*	C-12 C-13	12 12
P F	5360-690-0590	SPRING, HELICAL, TORSION: BUFFER SUPPORT 7793541 (19204)      A	EA	1	*	*	*	*	*	*	*	*	C-12	13
P F	1005-832-9610	SPRING, HELICAL, TORSION: BUFFER SUPPORT 11013364 (19204)      B	EA	1	*	*	*	*	*	*	*	*	C-12 C-13	13 13
P F	1005-690-0589	SUPPORT, BUFFER: 7793540 (19204)	EA	1	*	*	*	*	*	*	*	*	C-12 C-13	14 14
C P F	5305-690-0580	SCREW, MACHINE: RATE CONTROL GUIDE 7793520 (19204)	EA	1	*	*	*	*	*	*	*	*	C-12 C-13	15 15
N P F	5305-984-7362	SCREW, MACHINE: RATE CONTROL GUIDE SUPPORT	EA	1	*	*	*	*	*	*	*	*	C-12 C-13	16 16
P F	1005-690-0305	GUIDE, RATE CONTROL: 7793581 (19204)	EA	1	*	*	*	*	*	*	*	*	C-12 C-13	17 17

TM 9-1005-233-24



**Section IV. REPAIR PARTS LIST — Continued**

(1) SMR Code	(2) Federal Stock Number	(3) Description  Reference Number & Mfr. Code                      Usable On Code		(4) Unit of meas	(5) Qty inc. in unit	(6) 30-day DS maint allowance			(7) 30-day GS maint allowance			(8) 1-yr alw per 100 quip cnt- gcy	(9) Depot maint alw per 100 equip	(10) Illustration	
						(a)	(b)	(c)	(a)	(b)	(c)			(a) Figure No.	(b) Item No.
						1-20	21-50	51-100	1-20	1-50	51-100				
P F	1005-690-0611	SLIDE, RATE CONTROL: 7793582 (19204)	EA	1	*	*	*	*	*	*	*	*	C-12	18	
C P F	1005-690-0577	SPRING, HELICAL, COMPRESSION: RATE CONTROL SLIDE 7793517 (19204)	EA	1	*	*	*	*	*	*	*	*	C-13	18	
P F	1005-690-0575	SUPPORT, GUIDE, RATE CONTROL: 7793515 (19204)	EA	1	*	*	*	*	*	*	*	*	C-12	20	
C P F	5315-807-4959	PIN, SPRING: S, PHOS-CTD, 3/32 X 3/8 LG MS 39086-78 (96906)	EA	2	REF	REF	REF	REF	REF	REF	REF	REF	C-13	20	
P F	1005-084-7630	ROD ASSEMBLY : COVER LATCH 7792833 (19204)	EA	2	*	*	*	*	*	*	*	*	C-12	21	
C P F	5315-824-7426	PIN, SPRING: HV-DUTY S, PHOS-CTD, 1/16 NOM DIA. 070 MAX DIA, 3/8 LG MS 39086-53 (96906)	EA	2	REF	REF	REF	REF	REF	REF	REF	REF	C-13	21	
C P F	1005-923-4254	LATCH ASSEMBLY, COVER : 11013408 (19204)	EA	2	*	*	*	*	*	*	*	*	C-12	22	
XIF	.....	ROD: COVER LATCH 7793629 (19204)	EA	2	..	..	..	..	..	..	..	..	C-12	22	
P F	1005-690-0582	SPRING, COVER LATCH ROD: 7793522 (19204)	EA	2	*	*	*	*	*	*	*	*	C-13	23	
X	.....	SHELL ASSEMBLY: RECEIVER W/CAMS 7793639 (19204)	EA	1	..	..	..	..	..	..	..	..	C-12	24	
X		SHELL ASSEMBLY: RECEIVER W/CAMS 11013374 (19204)	EA	1	..	..	..	..	..	..	..	..	C-13	24	
P H	5320-828-1955	RIVET, SOLID: 9 DEG CK-HD, S, 0.096 SHANK DIA, 0.375 LG 7792823 (19204)	EA	14	..	..	..	*	*	*	*	*	C-11	25	
P H	5320-011-3226	RIVET, SOLID, FLUSH-CK-HD (90 DEG) S ANLD, 1/4 X 9/16, RIVET CAM MS 35744-32 (96906)	EA	7	..	..	..	*	*	*	*	*	C-12	26	
P D	5320-011-2619	RIVET, SOLID: FLUSH-CK-HD, S, ANLD, 3/16 X 7/16 MS 35744-17 (96906)	EA	4	..	..	..	..	..	..	..	*	C-13	26	
N P D	1005-489-2585	DEFLECTOR, CARTRIDGE: 11013308 (19204)	EA	1	..	..	..	..	..	..	..	*	C-12	27	
N P D	1005-146-0808	CAM, HAMMER AND OPENING: 8448756 (19204)	EA	1	..	..	..	..	..	..	..	*	C-13	27	
N P D	1005-148-5277	CAM, CLOSING: 8448757 (19204)	EA	1	..	..	..	..	..	..	..	*	C-13	28	

## Section IV. REPAIR PARTS LIST — Continued

(1) SMR Code	(2) Federal Stock Number	(3) Description  Reference Number & Mfr. Code Usable On Code		(4) Unit of meas	(5) Qty inc. in unit	(6) 30-day DS maint allowance			(7) 30-day GS maint allowance			(8) 1-yr alw per 100 equip cnt- gcy	(9) Depot maint alw per 100 quip	(10) Illustration		
						(a) 1-20	(b) 21-50	(c) 51-100	(a) 1-20	(b) 21-50	(c) 51-100			(a) Figure No.	(b) Item No.	
P F	5320-256-3744	THE FOLLOWING ITEM IS USED TO SALVAGE COVER AND TRACK ASSEMBLY 7793643 RIVET, TINNERS: MS 51931-4 (96906)		P K		*	*	*	*	*	*	*				
P F	4010-221-0738	BULK ISSUE ITEMS CHAIN, WELDED: S, PHOS-CTD, 7/64 SIZE SHORT TWIST LINK, 25 LINKS PER FT (100 FT PER BOX) PR-C271 819880 (81348)		FT	*	1	1	*	1	1	12	2				

(1) SMR Code	(2) Federal Stock Number	(3) Description  Reference Number & Mfr. Code Usable On Code	(4) Unit of meas	(5) Qty inc. in unit	(6) 30-day DS maint allowance			(7) 30-day GS maint allowance			(8) 1-yr alw per 100 equip cnt- gcy	(9) Depot maint alw per 100 equip	(10) Illustration	
					(a)	(b)	(c)	(a)	(b)	(c)			(a) Figure No.	(b) Item No.
					1-20	21-50	1-100	1-20	21-50	51-100				
		TOOLS AND EQUIPMENT AUTHORIZED FOR UNIT REPLACEMENT												
C P O	1005-288-3565	SWAB, SMALL ARMS CLEANING: COTTON, 2½ SQ (1000 IN PG) 5019316 (19204)	PG	..	3	6	10	3	6	10	20			
R P C	1005-350-4100	BRUSH, CLEANING, SMALL ARMS: RECEIVER 8448466 (19204)	EA	..	2	4	6	2	4	6	72	..	C-14	11
C P C	1005-550-6573	CASE, SMALL ARMS CLEANING ROD: 5506573 (19204)	EA	.	1	1	2	1	1	2	24	..	C-14	2
C P C	1005-556-4174	BRUSH, CLEANING, SMALL ARMS: BORE 5564174 (19204)	EA	.	5	11	21	5	11	21	252	..	C-14	14
C P C	1005-689-9942	LOCK, BARREL BEARING: 7793523-2 (19204)	EA	..	*	1	2	*	1	2	24	..	C-1	2
C P C	1005-690-3115	BRUSH, CLEANING, SMALL ARMS: CHAMBER 7790452 (19204)	EA	..	2	4	6	2	4	6	72	..	C-14	10
C P C	1005-694-1662	BUFFER, CLEANING ROD: 7268275 (19204)	EA	.	1	2	4	1	2	4	48	..	C-14	4
C P C	1005-714-5250	BOX, SPARE PARTS: 7790683 (19204)	EA	.	*	1	2	*	1	2	24	..	C-14	12
C P C	1005-726-6109	ROD, SECTION, CLEANING, SMALL ARMS: 7266109 (19204)	EA	.	2	4	8	2	4	8	96	..	C-14	5
C P C	1005-726-6110	SWAB HOLDER SECTION, SMALL ARMS CLEANING ROD: 7266110 (19204)	EA	.	1	2	4	1	2	4	48	..	C-14	6
C P C	1005-793-6761	HANDLE ASSEMBLY: CLEANING ROD 7266115 (19204)	EA	.	*	1	2	*	1	2	24	..	C-14	3
C P C	1005-869-8817	SUPPRESSOR, FLASH: (M60A1 and M60A1E2 TANKS) 11013376 (19204)	EA	.	1	2	3	1	2	3	36	..	C-14	9
C P C	1005-922-9777	FLASH HIDER: S, PHOS-CTD, 1.030 BORE DIA, 5.280 O/A LG, W/MTG FACILITIES 11013420 (19204)	EA	.	1	2	3	1	2	3	36	..	C-14	13
C P C	1005-933-8070	EXTENSION, JACKET, BARREL: (FOR M60A1E2 TANK ONLY) 11013438 (19204)	EA	.	1	2	3	1	2	3	36	..	C-14	15
C P C	4933-652-9950	EXTRACTOR, RUPTURED CARTRIDGE CASE: 7790352 (19204)	EA	.	1	2	2	1	2	2	24	..	C-14	7
C P C	4933-733-4759	COMBINATION TOOL: 7791083 (19204)	EA	..	1	1	2	1	1	2	24	..	C-14	8
C P C	5120-242-5966	PUNCH, DRIVE, PIN: STRAIGHT, 3/4 IN LG, 1/8 IN DIA PT GGG-P-831 (81348)	EA	..	*	*	1	*	*	1	12	..	C-14	17

Section V. SPECIAL TOOLS LIST — Continued

78

TM 9-1005-233-24

(1) SMR Code	(2) Federal Stock Number	(3) Description	(4) Unit of meas	(5) Qty inc. in unit	(6) 30-day DS maint allowance			(7) 30-day GS maint allowance			(8) 1-yr alw per 100 equip cnt- gcy	(9) Depot maint alw per 100 equip	(10) Illustration	
					(a)	(b)	(c)	(a)	(b)	(c)			(a) Figure No.	(b) Item No.
					1-20	21-50	51-100	1-20	21-50	51-100				
C P C	5120-264-3793	WRENCH: AUTO, ADJ, 15 IN LG O/A, 0 TO 5/8 MIN JAW OPENING CAP GGG-W-631A TYPE E2 (81348)	EA		*	*	1	*	*	1	12	.	C-14	1
C P C	9150-889-3522	LUBRICATING OIL, SEMIFLUID: (LSA) 4 OZ BOTTLE 8436793 (19207)	OZ		3	6	11	3	6	11	132	.	C-14	16
C P F R	4933-775-0366	TOOLS AND EQUIPMENT THE FOLLOWING BASIC SMALL ARMS DIRECT AND GENERAL SUPPORT MAINTENANCE TOOL KIT IS AUTHORIZED, AS REQUIRED TO ALL MAINTENANCE SUPPORT UNITS WITH A SMALL ARMS REPAIR MISSION. THE 30 DAY LEVEL IS NOT APPLICABLE TOOL SET, DIRECT AND GENERAL SUPPORT MAINTENANCE, BASIC SMALL ARMS: 8426358 (19204) SEE SC-4933-95-CL-E04 FOR COMPONENTS. THE FOLLOWING TOOL SETS ARE REQUISITIONED AND ISSUED, IF NOT OTHERWISE AUTHORIZED, TO MAINTENANCE UNITS PERFORMING DIRECT AND GENERAL SUPPORT, OR DEPOT MAINTENANCE OF THE MAJOR ITEMS. THE COMPLETE SET MAY BE REQUISITIONED UNDER ITS OWN STOCK NUMBER. ANY INDIVIDUAL ITEM MAY ALSO BE REQUISITIONED UNDER ITS OWN STOCK NUMBER FOR REPLACEMENT PURPOSES.	SE		*	*	*	*	*	*	*	.		
C P F R	4933-999-4810	TOOL SET, DIRECT AND GENERAL SUPPORT MAINTENANCE: 5910418 (19204) REFER TO SC 4933-95-CL-E29 FOR COMPONENTS.	EA		*	*	*	*	*	*	*	.		
C P D R	4933-714-2807	TOOL SET, DEPOT MAINTENANCE: 7142807 (19204) SEE SC 4933-95-CL-E05 FOR COMPONENTS. THE FOLLOWING INDIVIDUAL ITEMS ARE AUTHORIZED FOR DEPOT REBUILD PROGRAMS ONLY.	EA		..	..	..	..	..	..	..	*		
C P D	4933-838-5472	COVER, PROOF FIRING: 7273975 (19204)	EA		..	..	..	..	..	..	..	*		

**Section V. SPECIAL TOOLS LIST — Continued**

(1) SMR Code	(2) Federal Stock Number	(3) Description  Reference Number & Mfr. Code                      Usable On Code		(4) Unit of meas	(5) Qty inc. in unit	(6) 30-day DS maint allowance			(7) 30-day GS maint allowance			(8) 1-yr alw per 100 quip cnt- gcy	(9) Depot maint alw per 100 equip	(10) Illustration	
						(a)	(b)	(c)	(a)	(b)	(c)			(a) Figure No.	(b) Item No.
						1-20	21-50	51-100	1-20	21-50	51-100				
C P D	4933-916-9207	STAND, FIRING: 7273901 (19204)		EA	1	..	..	..	..	..	..	..	*		
C P D	4933-917-5634	COMPARATOR, OPTICAL: 7315513 (19204)		EA	1	..	..	..	..	..	..	..	*		
C P D	1005-336-0212	SPECIAL PACKAGING MATERIAL THE VOLATILE CORROSION INHIBITOR TREATED ITEM, LISTED BELOW, IS REQUIRED FOR PRESERVATION WHEN THE BARREL IS PACKAGED FOR SHIPMENT AND STORAGE. TUBE, BORE, VCI TREATED: 7266316 (19204)		EA	..	..	..	..	..	..	..	..	*		
P F	4010-221-0738	BULK ISSUE ITEMS CHAIN, WELDED: S, PHOS-CTD, 7/64 SIZE SHORT TWIST LINK, 25 LINKS PER FT (100 FT PER BOX) PR-C271 819880 (81348)		FT	..	*	*	*	*	*	*	*	*		

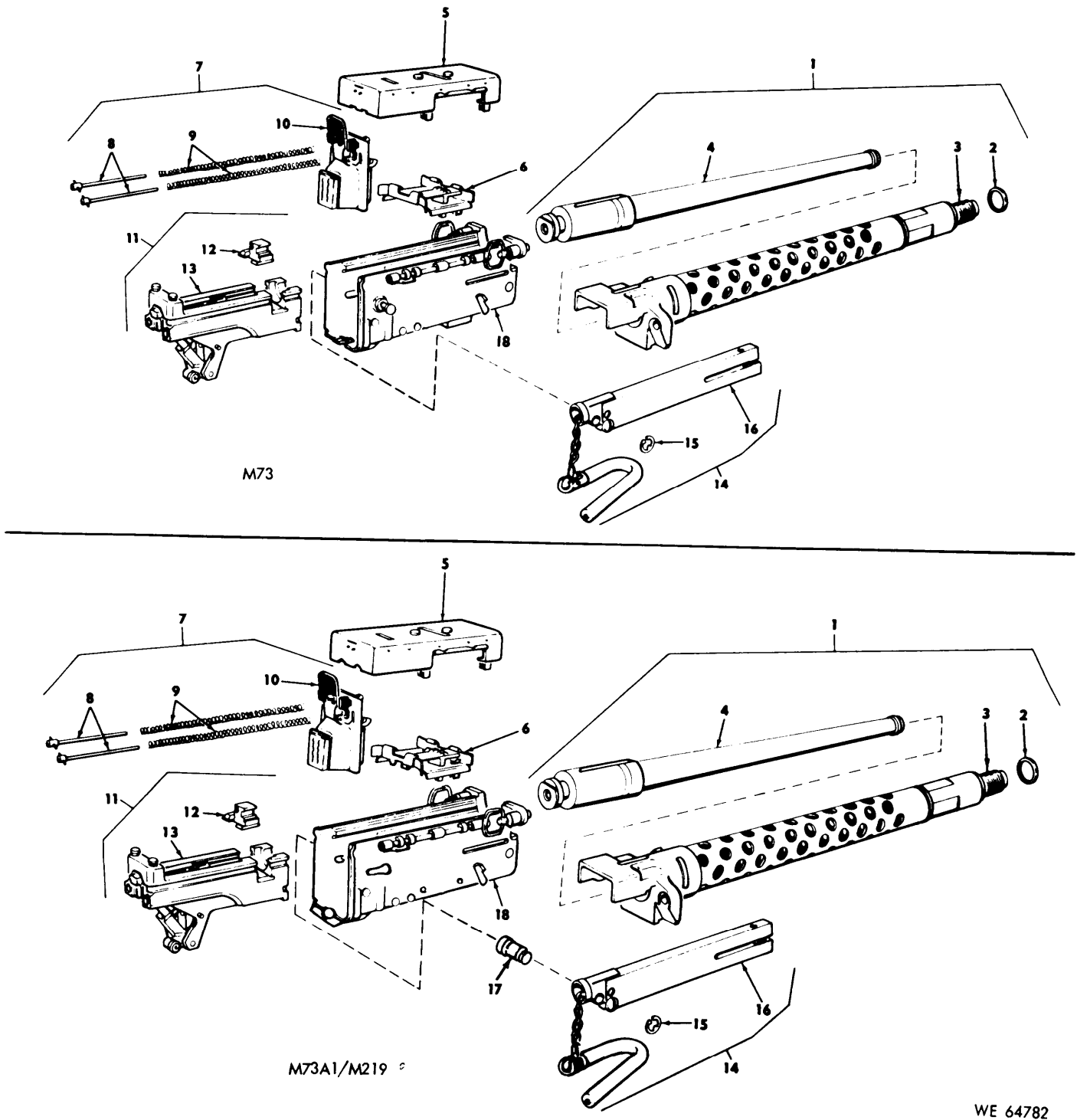

WE 64782

Figure C-1. Machine Guns, 7.62-MM, M73, M73A1, and M219, major groups and assemblies— partial exploded view.

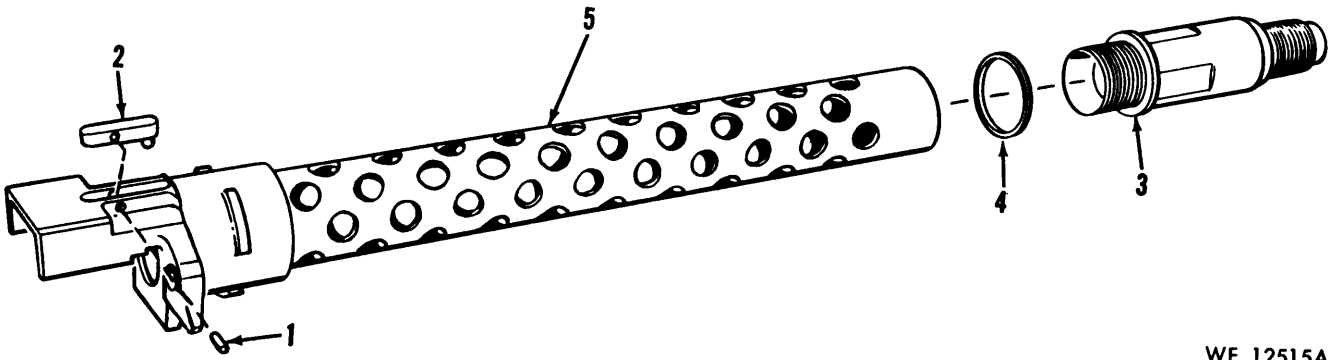

WE 12515A

Figure C-2. Jack assembly w/ bearing—exploded view.

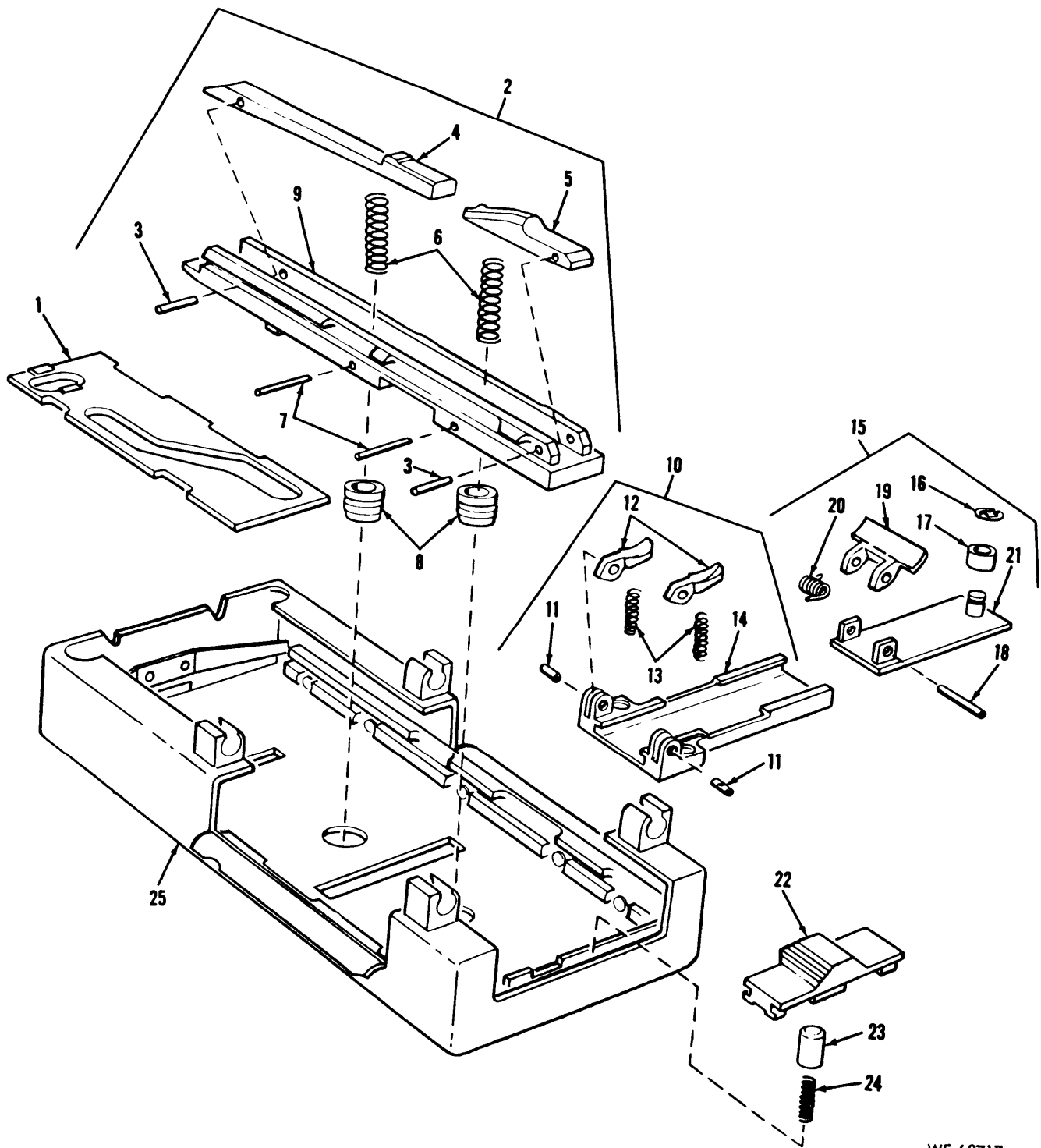

WE 68717

Figure C-3. Cover assembly—exploded view.



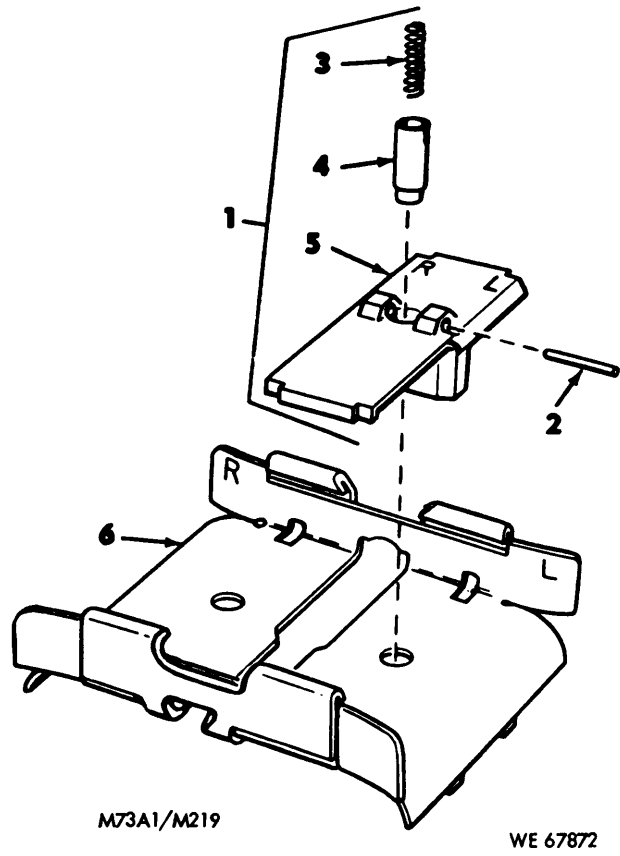
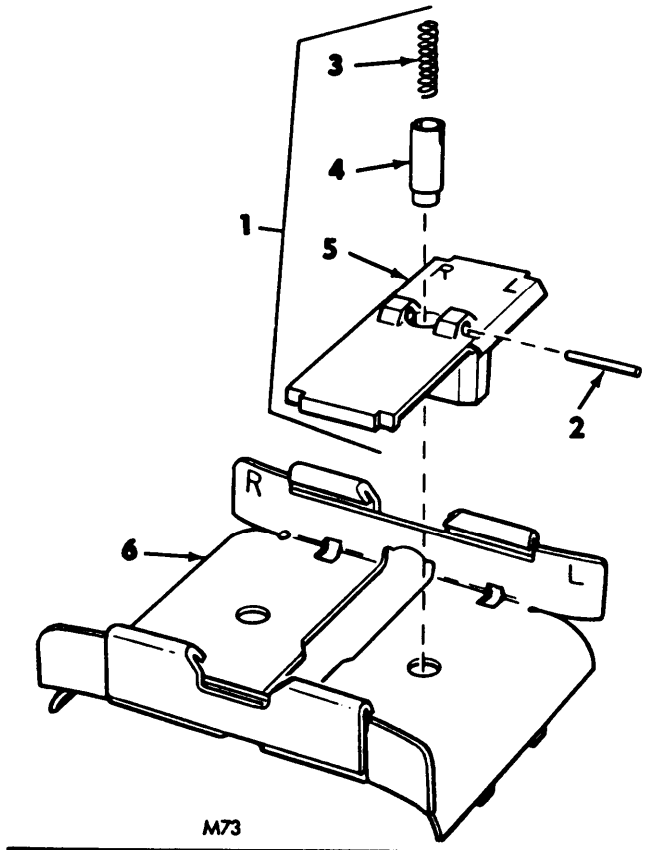
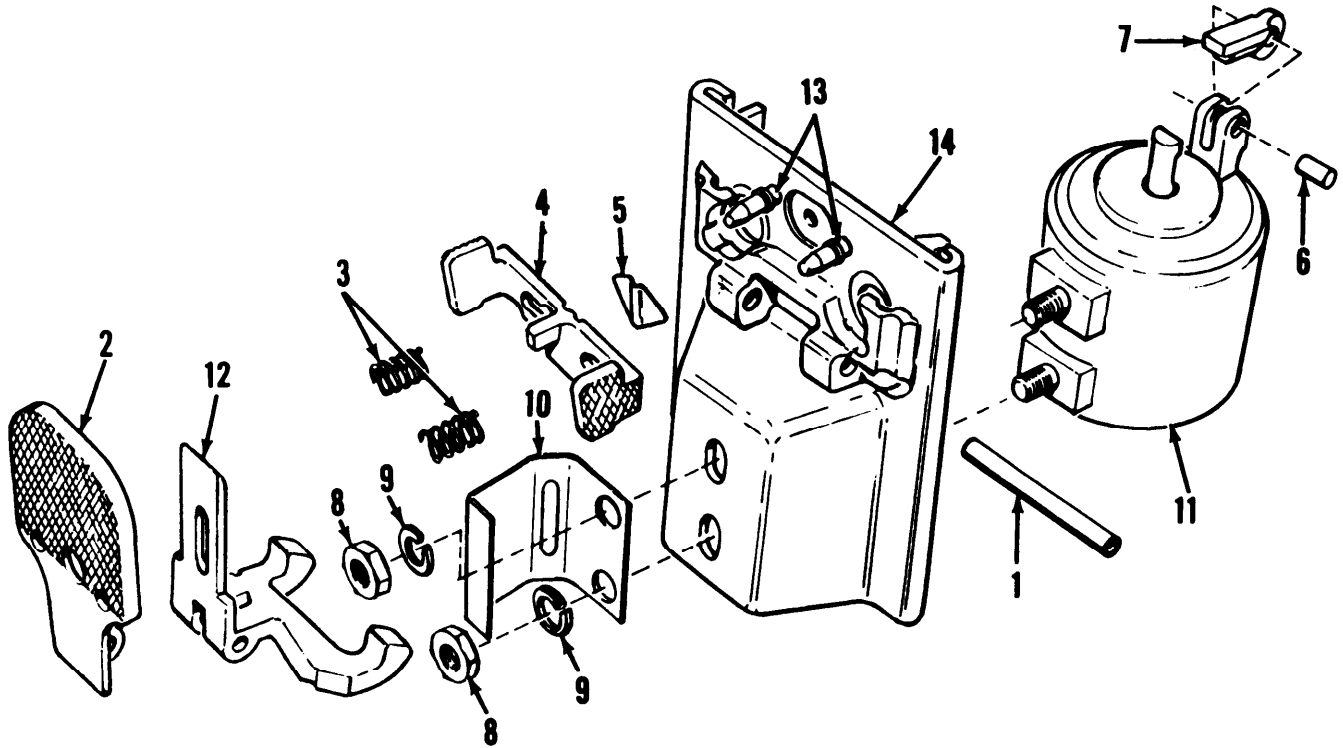
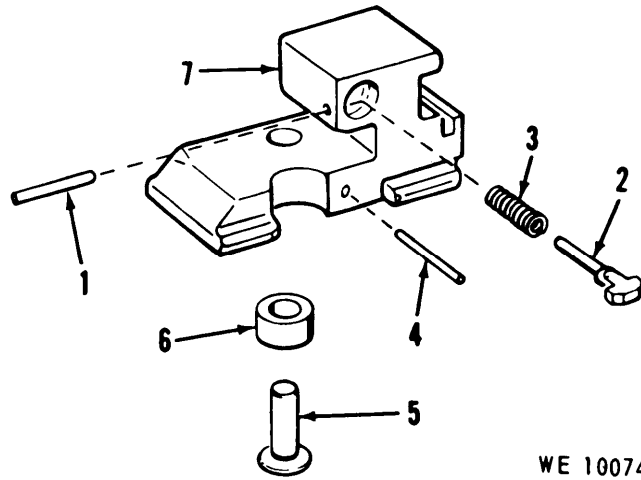

Figure C-4. Feed tray group—exploded view.



WE 63649

Figure C-5. Back plate assembly w/solenoid—exploded view.



WE 10074

Figure C-6. Breechblock assembly—exploded view.

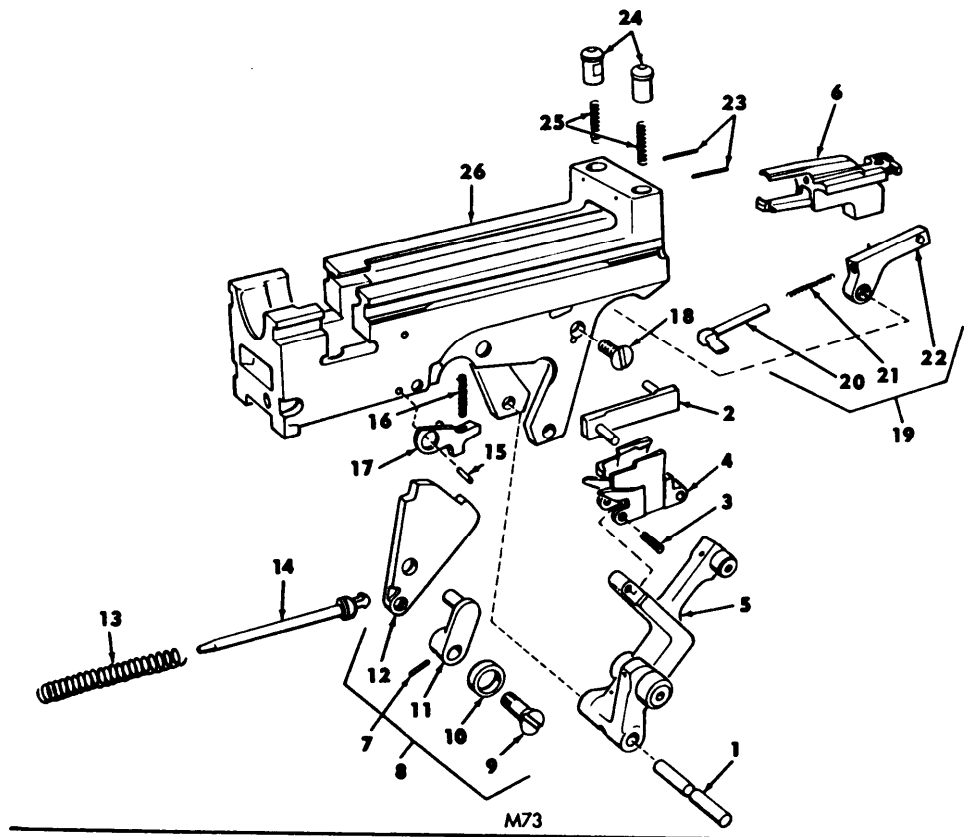

M73

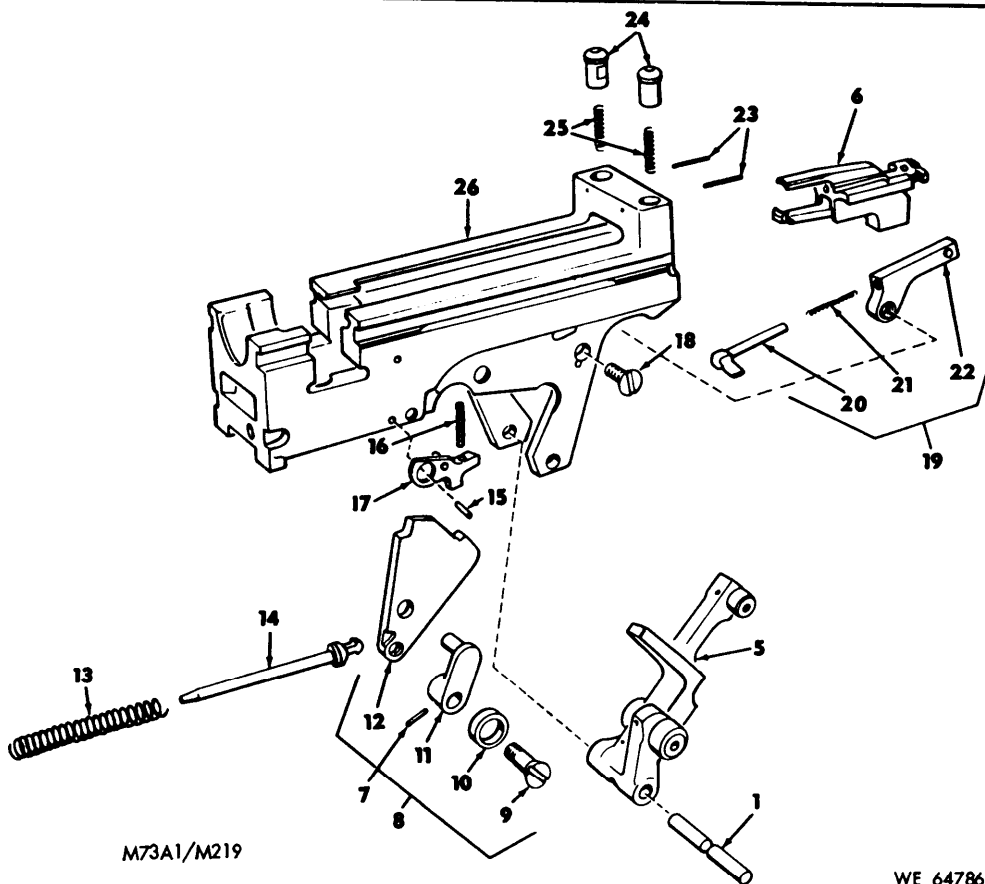

M73A1/M219

WE 64786

Figure C-7. Barrel extension assembly—exploded view.

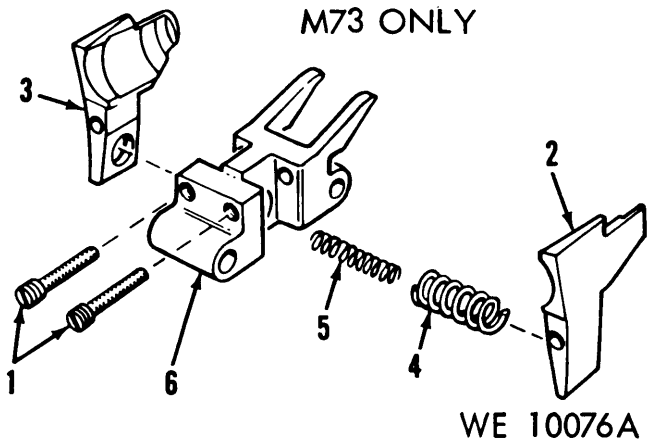

Figure C-8. Carrier assembly—exploded view.

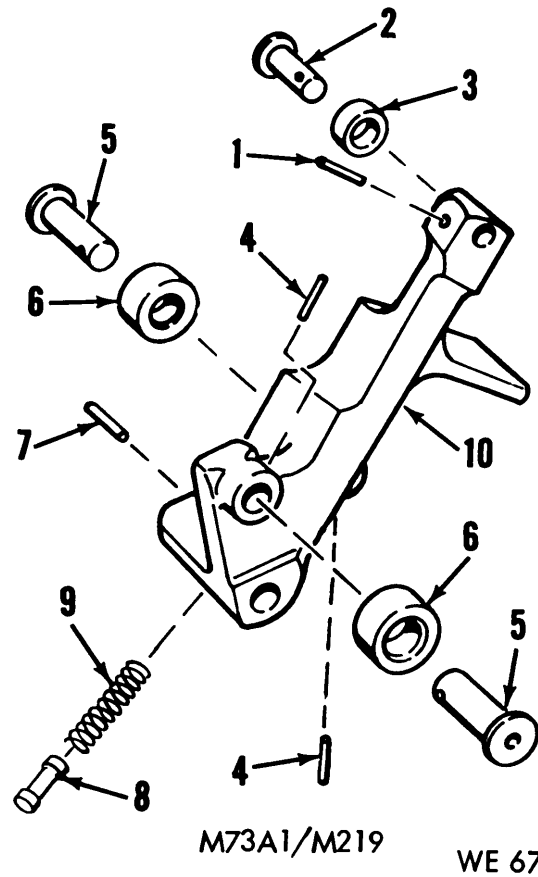
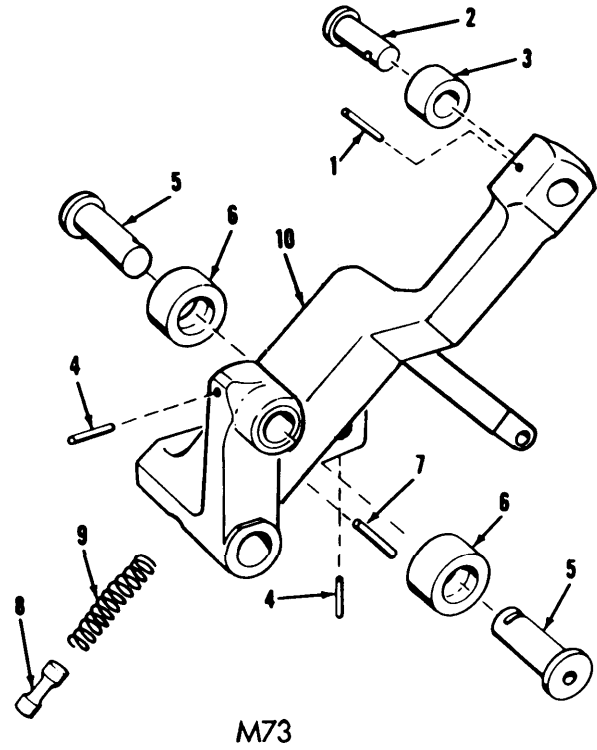

Figure C-9. Lever assembly—exploded view.

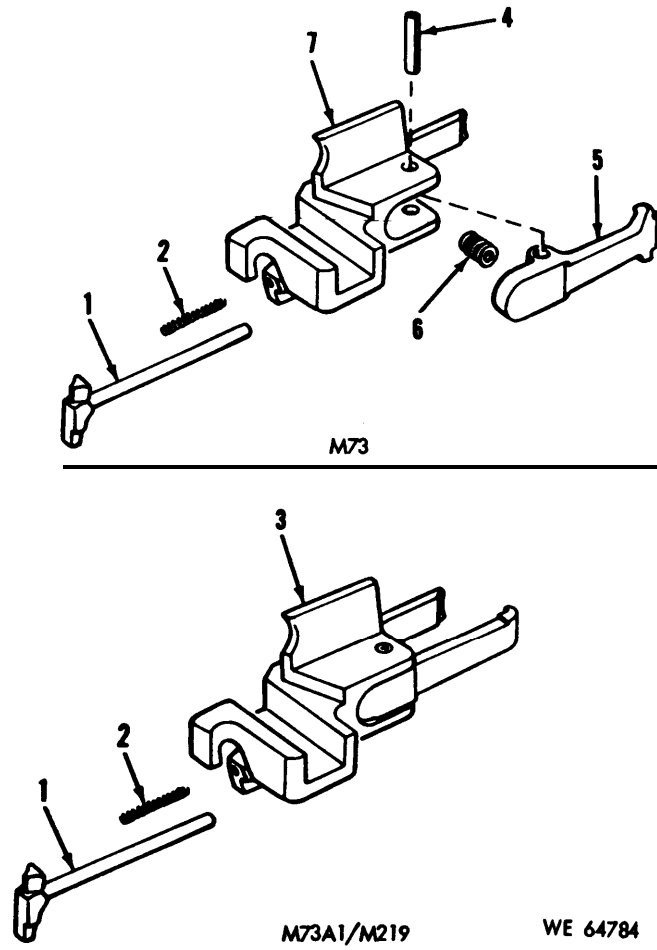
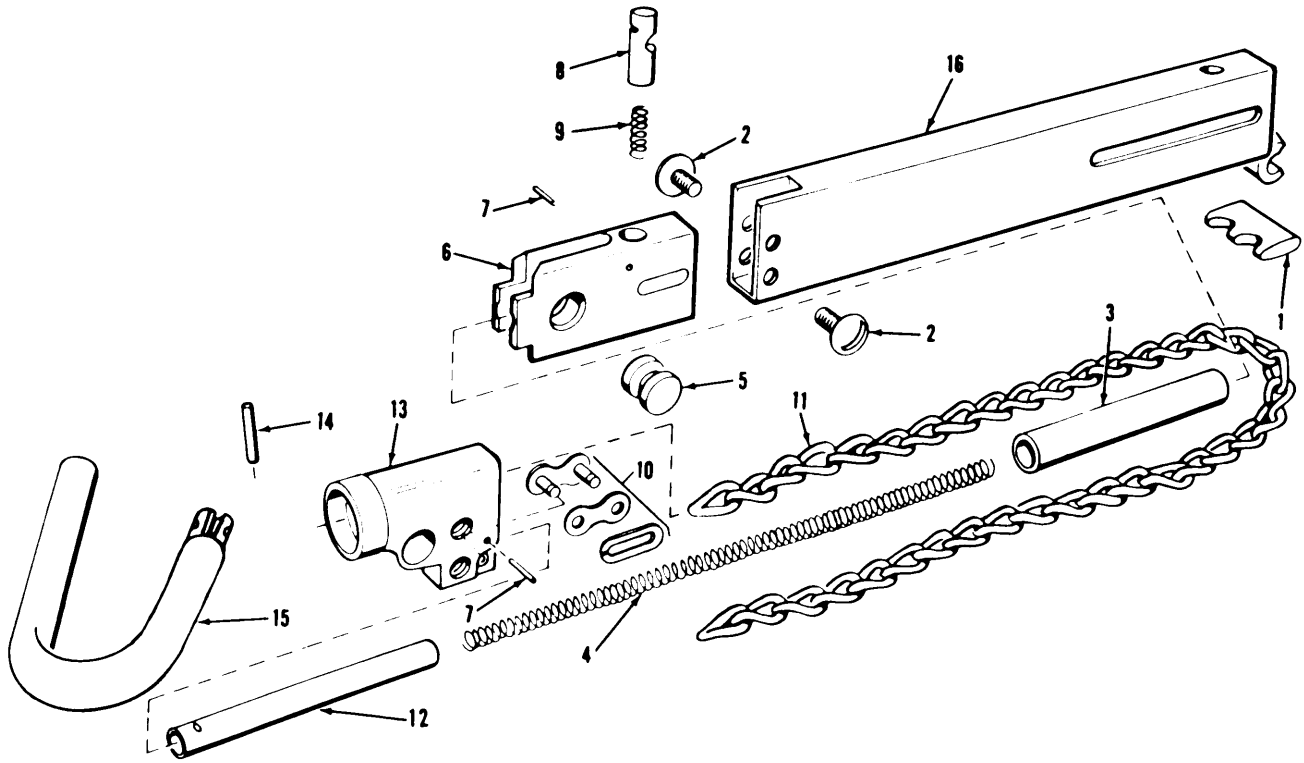

Figure C-10. Rammer assembly—exploded view.



WE 10079A

Figure C-11. Charger assembly—exploded view.

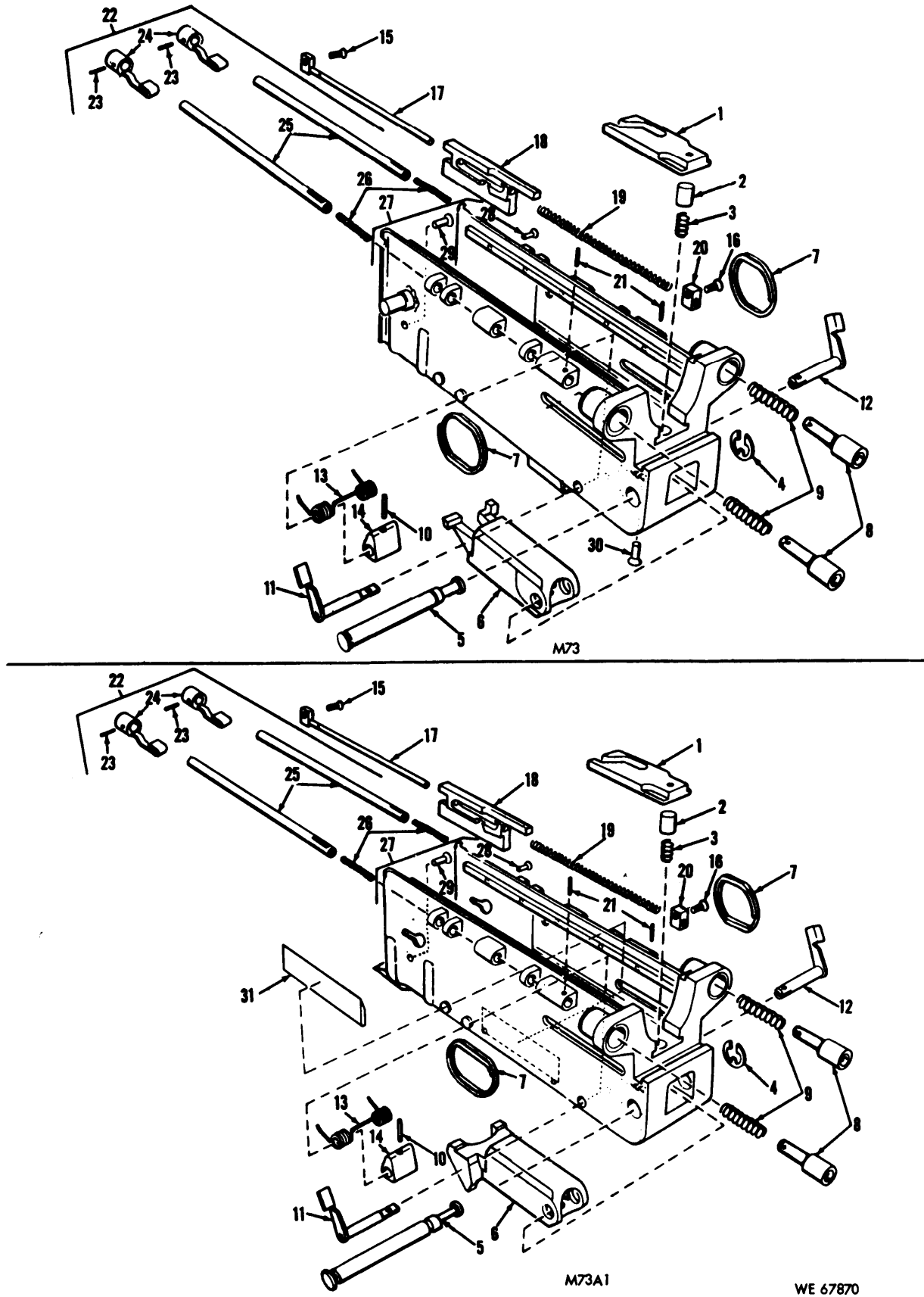

Figure C-12. Receiver assembly (M73 and M73A1 only)—exploded view.

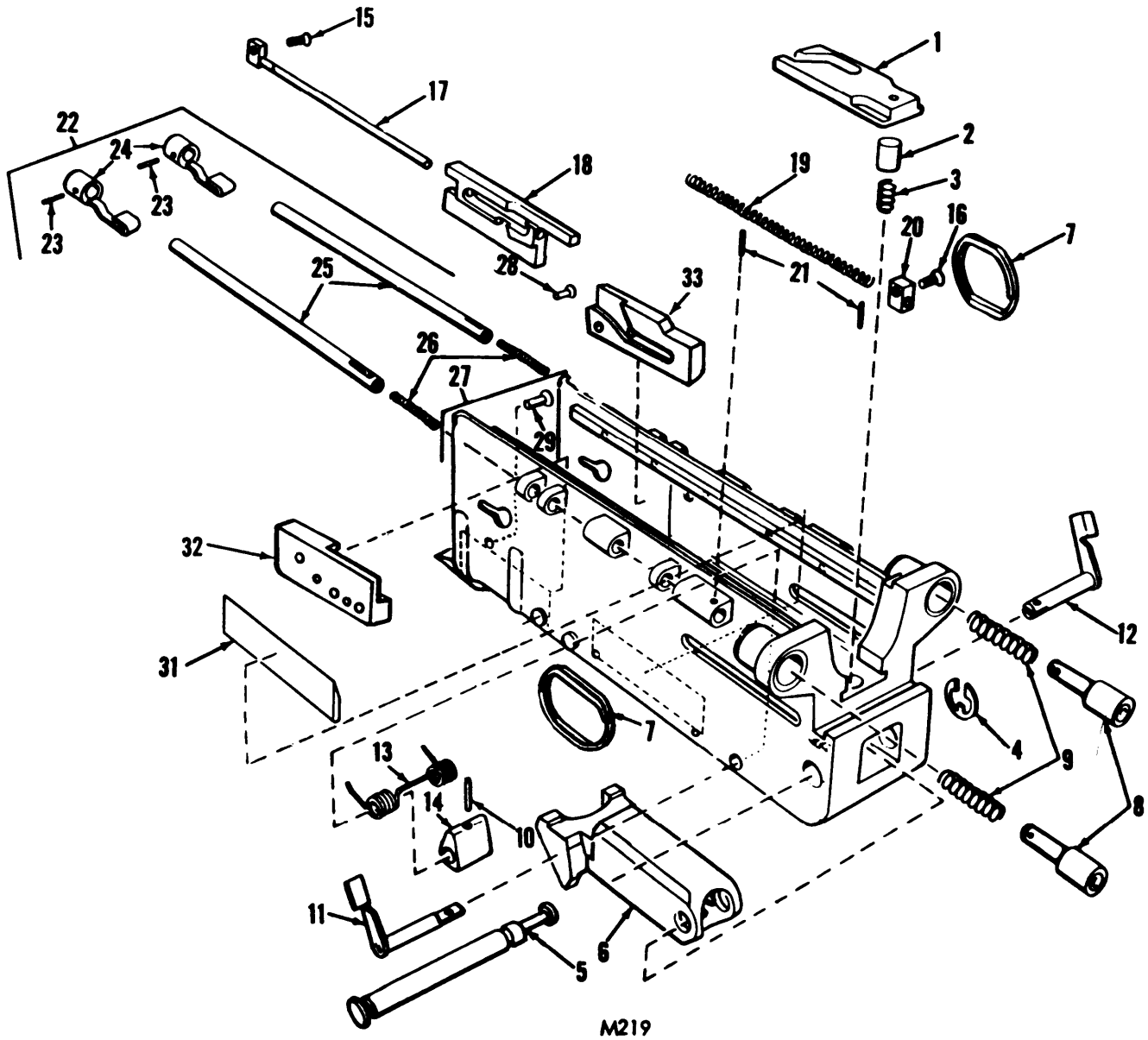
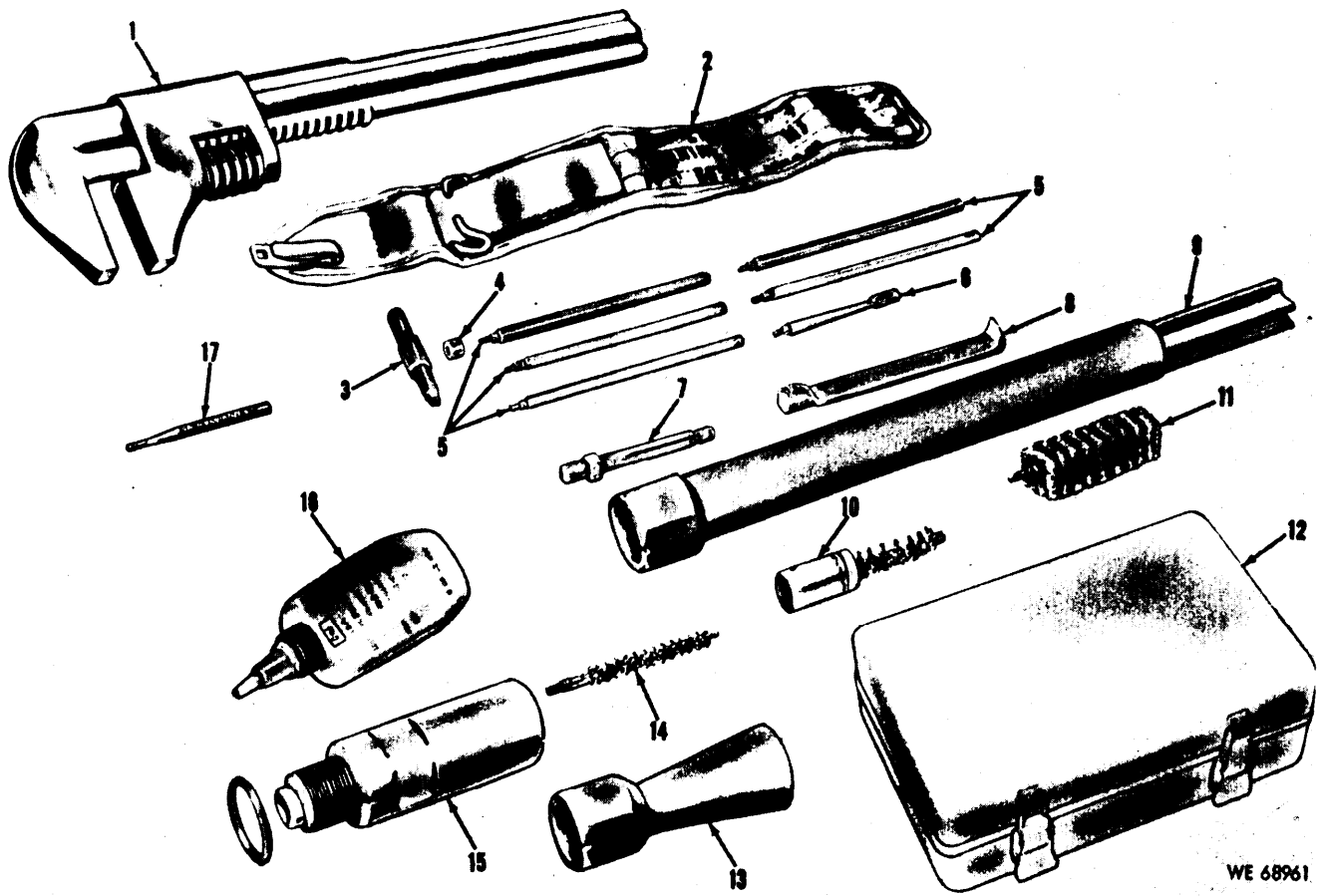

Figure C-13. Receiver assembly (M219 only)-exploded view.





WE 68961

Figure C-14. Tools and equipment.

Section VI. FEDERAL STOCK NUMBER AND REFERENCE NUMBER INDEX

STOCK NUMBER	FIGURE NO	ITEM NO	STOCK NUMBER	FIGURE NO	ITEM NO
1005-044-1896	C-3	19	1005-690-0601	C-6	2
1005-084-7630	C-12	22	1005-690-0603	C-7	10
1005-146-0808	C-13	32	1005-690-0605	C-3	5
1005-148-5277	C-13	33	1005-690-0611	C-12	18
1005-240-5725	C-11	10		C-13	18
1005-350-4100	C-14	11	1005-690-0618	C-3	22
1005-462-8634	C-10	3	1005-690-0619	C-3	9
1005-489-2585	C-12	31	1005-690-0620	C-9	10
1005-550-6573	C-14	2	1005-690-0626	C-3	12
1005-556-4174	C-14	14	1005-690-0628	C-10	7
1005-689-9939	C-2	3	1005-690-3115	C-14	10
1005-689-9941	C-2	4	1005-694-1662	C-14	4
1005-689-9942	C-1	2	1005-714-5250	C-14	12
1005-690-0294	C-3	21	1005-715-7693	C-12	2
1005-690-0297	C-11	1		C-13	2
1005-690-0299	C-11	3	1005-715-7694	C-12	1
1005-690-0305	C-12	17		C-13	1
	C-13	17	1005-715-7695	C-11	16
1005-690-0306	C-1	8	1005-715-7698	C-11	13
1005-690-0308	C-12	12	1005-726-2853	C-12	3
	C-13	12		C-13	3
1005-690-0309	C-3	1	1005-726-6109	C-14	5
1005-690-0311	C-12	11	1005-726-6110	C-14	6
	C-13	11	1005-769-3094	C-7	17
1005-690-0314	C-10	5	1005-769-3096	C-9	8
1005-690-0315	C-3	10	1005-788-9140	C-5	11
1005-690-0316	C-3	4	1005-793-6761	C-14	3
1005-690-0322	C-4	6	1005-796-7038	C-11	15
1005-690-0323	C-3	25	1005-832-9610	C-12	13
1005-690-0329	C-10	1		C-13	13
1005-690-0536	C-10	6	1005-832-9612	C-1	13
1005-690-0538	C-10	2	1005-832-9613	C-1	17
1005-690-0543	C-7	21	1005-832-9615	C-4	6
1005-690-0549	C-3	17	1005-832-9616	C-12	6
1005-690-0550	C-3	23		C-13	6
1005-690-0551	C-7	25	1005-832-9617	C-9	10
1005-690-0558	C-11	9	1005-832-9618	C-9	3
1005-690-0561	C-11	4	1005-856-7995	C-1	9
1005-690-0562	C-3	13	1005-859-7934	C-2	2
1005-690-0566	C-7	13	1005-869-8817	C-14	9
1005-690-0568	C-12	9	1005-875-9768	C-5	3
	C-13	9	1005-904-9296	C-12	6
1005-690-0569	C-3	24	1005-912-1143	C-8	6
	C-4	3	1005-921-6316	C-12	8
	C-6	3		C-13	8
1005-690-0570	C-3	6	1005-921-6317	C-1	12
1005-690-0575	C-12	20	1005-922-8058	C-11	5
	C-13	20	1005-922-8059	C-11	6
1005-690-0577	C-12	19	1005-922-9777	C-14	13
	C-13	19	1005-923-4254	C-12	24
1005-690-0578	C-7	16		C-13	24
1005-690-0582	C-12	26	1006-924-1773	C-2	5
	C-13	26	1005-930-4803	C-5	12
1005-690-0589	C-12	14	1005-933-8070	C-14	15
	C-13	14	1005-937-8255	C-7	26
1005-690-0591	C-4	4	1005-937-8256	C-1	13
1005-690-0592	C-3	8	1005-937-8257	C-7	24
1005-690-0595	C-11	8	1005-950-0790	C-4	1
1005-690-0596	C-11	12	1005-966-9315	C-5	10
1005-690-0597	C-9	5	1005-972-0196	C-1	4
1005-690-0598	C-9	6	1005-973-0245	C-8	2
	C-6	5	1005-973-0246	C-8	3
1005-690-0599	C-9	2	1005-973-0249	C-8	4
1005-690-0600	C-6	6	1005-973-0250	C-8	5
	C-9	3	1005-973-0251	C-7	20

**Section VI. FEDERAL STOCK NUMBER AND REFERENCE  
NUMBER INDEX—Continued**

STOCK NUMBER	FIGURE NO	ITEM NO	STOCK NUMBER	FIGURE NO	ITEM NO
1005-973-0331	C-12	7	5315-810-3703	C-6	1
	C-13	7	5315-810-5133	C-2	1
1005-986-0263	C-7	2	5315-812-0762	C-11	7
1005-990-9283	C-5	5	5315-812-1005	C-7	7
1005-990-9285	C-5	2		C-9	4
1005-990-9286	C-5	14	5315-812-1007	C-3	3
1005-990-9289	C-7	12		C-7	3
1005-990-9290	C-7	14		C-11	14
1005-990-9295	C-7	11	5315-812-9525	C-3	7
1005-999-0479	C-7	22	5315-814-3533	C-6	4
1005-999-4687	C-5	1		C-7	23
1005-999-4688	C-5	7	5315-824-7426	C-9	1
1005-999-4689	C-5	4		C-12	23
4933-652-9950	C-14	7		C-13	23
4933-733-4759	C-14	8	5315-834-8712	C-10	4
5120-242-5966	C-14	17	5315-839-0901	C-12	10
5120-264-3793	C-14	1		C-13	10
5305-690-0552	C-8	1	5315-874-2511	C-7	7
5305-690-0580	C-12	15	5315-990-9287	C-5	13
	C-13	15	5315-990-9288	C-12	5
5305-690-0602	C-7	9		C-13	5
5305-690-0607	C-7	18	5315-999-4687	C-5	1
5305-804-1511	C-11	2	5320-011-2619	C-12	30
5305-984-7362	C-12	16		C-13	30
	C-13	16	5320-011-3226	C-12	29
5310-274-8715	C-5	6		C-13	29
5310-971-7989	C-5	8	5320-828-1955	C-12	28
5315-690-0544	C-3	18		C-13	28
5315-690-0565	C-3	11	5340-952-4705	C-9	9
5315-690-0572	C-4	2	5360-690-0546	C-3	20
5315-690-0579	C-5	6	5360-690-0590	C-12	13
5315-690-0632	C-7	1		C-1	15
5315-807-4959	C-7	15	5365-209-6975	C-12	4
	C-9	7		C-13	4
	C-12	21	5365-282-2426	C-3	16
	C-13	21	9150-889-3522	C-13	16

REFERENCE NUMBER	MFG CODE	FIG NO	ITEM NO	REFERENCE NUMBER	MFG CODE	FIG NO	ITEM NO
GGG-P-831	81348	C-14	17	MS 39086-78	96906	C-7	15
GGG-W-631A Type E2	81348	C-14	1			C-9	7
MS 16633-3018	96906	C-3	16			C-12	21
MS 16633-3037	96906	C-1	15			C-13	21
		C-12	4	MS 39086-79	96906	C-7	7
		C-13	4	MS 39086-81	96906	C-12	10
MS 24585-75	96906	C-9	9			C-13	10
MS 35191-271	96906	C-12	16	MS 39086-83	96906	C-3	7
		C-13	16	MS 39086-91	96906	C-3	3
MS 35338-63	96906	C-5	9			C-7	3
MS 35691-5	96906	C-5	8			C-11	14
MS 35744-17	96906	C-12	30	11013349	19204	C-2	3
		C-13	30	11013350	19204	C-7	26
MS 35744-32	96906	C-12	29	11013360	19204	C-1	13
		C-13	29	11013362	19204	C-7	6
MS 39086-204	96906	C-2	1	11013364	19204	C-12	13
MS 39086-52	96906	C-7	7			C-13	13
		C-9	4	11013367	19204	C-5	12
MS 39086-53	96906	C-9	1	11013368	19204	C-12	31
		C-12	23			C-13	31
		C-13	23	11013373	19204	C-1	18
MS 39086-54	96906	C-11	7	11013374	19204	C-12	27
MS 39086-58	96906	C-6	4			C-13	27
		C-7	23	11013376	19204	C-14	9
MS 39086-68	96906	C-6	1	11013377	19204	C-8	6

Section VI. FEDERAL STOCK NUMBER AND REFERENCE  
NUMBER INDEX—Continued

REFERENCE NUMBER	MFG CODE	FIG NO	ITEM NO	REFERENCE NUMBER	MFG CODE	FIG NO	ITEM NO
11013378	19204	C-7	4	7792893	19204	C-8	5
11013381	19204	C-12	8	7792894	19204	C-7	20
		C-13	8	7792898	19204	C-3	19
11013382	19204	C-11	5	7792899	19204	C-7	11
11013383	19204	C-11	6	7792908	19204	C-7	8
11013394	19204	C-4	5	7792919	19204	C-5	10
11013395	19204	C-4	1	7793173-2	19204	C-11	11
11013397	19204	C-12	6	7793461	19204	C-10	6
11013398	19204	C-5	1	7793463	19204	C-10	2
11013400	19204	C-2	5	7793468	19204	C-7	21
11013401	19204	C-1	3	7793470	19204	C-3	18
11013402	19204	C-7	22	7793473	19204	C-3	20
11013403	19204	C-7	24	7793478	19204	C-3	17
11013408	19204	C-12	24	7793479	19204	C-3	23
		C-13	24	7793481	19204	C-7	25
11013417	19204	C-5	7	7793482	19204	C-8	1
11013418	19204	C-5	4	7793489	19204	C-11	9
11013420	19204	C-14	13	7793493	19204	C-11	4
11013421	19204	C-6	7	7793496	19204	C-3	13
11013422	19204	C-1	12	7793501	19204	C-3	11
11013423	19204	C-5	5	7793504	19204	C-7	13
11013424	19204	C-5	2	7793506	19204	C-12	9
11013427	19204	C-5	14			C-13	9
11013429	19204	C-5	13	7793507	19204	C-3	24
11013432	19204	C-1	13			C-4	3
11013433	19204	C-12	5			C-6	3
		C-13	5	7793508	19204	C-3	6
11013434	19204	C-1	17	7793512	19204	C-4	2
11013436	19204	C-12	7	7793515	19204	C-12	20
		C-13	7			C-13	20
11013437	19204	C-1	10	7793517	19204	C-12	19
11013438	19204	C-14	15			C-13	19
11013441	19204	C-4	6	7793518	19204	C-7	16
11013442	19204	C-12	6	7793519	19204	C-5	6
		C-13	6	7793520	19204	C-12	15
11013445	19204	C-9	10			C-13	15
11013446	19204	C-7	5	7793522	19204	C-12	26
11013447	19204	C-9	3			C-13	26
5506573	19204	C-14	2	7793523-1	19204	C-2	4
5564174	19204	C-14	14	7793523-2	19204	C-1	2
7266109	19204	C-14	5	7793525	19204	C-12	3
7266110	19204	C-14	6			C-13	3
7266115	19204	C-14	3	7793540	19204	C-12	14
7268275	19204	C-14	4			C-13	14
7790352	19204	C-14	7	7793541	19204	C-12	13
7790452	19204	C-14	10	7793542	19204	C-3	21
7790683	19204	C-14	12	7793543	19204	C-4	4
7790951	19204	C-11	15	7793544	19204	C-3	8
7791083	19204	C-14	8	7793551	19204	C-11	1
7792823	19204	C-12	28	7793552	19204	C-11	8
		C-13	28	7793554	19204	C-11	3
7792827	19204	C-8	2	7793555	19204	C-11	12
7792828	19204	C-8	3	7793557	19204	C-9	5
7792833	19204	C-12	22	7793558	19204	C-9	6
		C-13	22	7793559	19204	C-6	5
7792838	19204	C-1	9			C-9	2
7792854	19204	C-2	2	7793560	19204	C-6	6
7792870	19204	C-11	2			C-9	3
7792871	19204	C-5	3	7793561	19204	C-6	2
7792874	19204	C-1	4	7793567	19204	C-7	9
7792878	19204	C-7	12	7793568	19204	C-7	10
7792879	19204	C-7	14	7793571	19204	C-3	5
7792890	19204	C-7	2	7793574	19204	C-7	18
7792892	19204	C-8	4	7793579	19204	C-3	15

**Section VI. FEDERAL STOCK NUMBER AND REFERENCE  
NUMBER INDEX—Continued**

<u>REFERENCE NUMBER</u>	<u>MFG CODE</u>	<u>FIG NO</u>	<u>ITEM NO</u>	<u>REFERENCE NUMBER</u>	<u>MFG CODE</u>	<u>FIG NO</u>	<u>ITEM NO</u>
7793581	19204	C-12	17	7793618	19204	C-3	12
		C-13	17	7793629	19204	C-12	25
7793582	19204	C-12	18			C-13	25
		C-13	18	7793639	19204	C-12	27
7793583	19204	C-1	8	7793641	19204	C-4	6
7793592	19204	C-12	2	7793642	19204	C-10	7
		C-13	2	7793643	19204	C-3	25
7793593	19204	C-12	12	7793647	19204	C-1	18
		C-13	12	7793648	19204	C-1	5
7793595	19204	C-3	14	7793655	19204	C-7	17
7793598	19204	C-3	22	7793660	19204	C-10	1
7793599	19204	C-3	9	7793662	19204	C-9	8
7793600	19204	C-3	1	7793663	19204	C-7	1
7793601	19204	C-9	10	7793677	19204	C-11	16
7793604	19204	C-12	11	7793681	19204	C-11	13
		C-13	11	7793684	19204	C-1	16
7793609	19204	C-10	5	7793702	19204	C-5	11
7793610	19204	C-3	10	7793748	19204	C-10	4
7793611	19204	C-7	6	8436793	19207	C-14	16
7793612	19204	C-7	5	8448401	19204	C-10	3
7793613	19204	C-3	2	8448451	19204	C-11	10
7793614	19204	C-12	1	8448466	19204	C-14	11
		C-13	1	8448756	19204	C-13	32
7793617	19205	C-3	4	8448757	19204	C-13	33

**By Order of the Secretary of the Army:**

**Official:**

**VERNE L. BOWERS,**  
*Major General, United States Army,*  
*The Adjutant General.*

**W. C. WESTMORELAND,**  
*General, United States Army,*  
*Chief of Staff.*

DISTRIBUTION:

To be distributed in accordance with DA Form 1240 (qty rqr block no. 104) Organizational Maintenance requirements for Machine Gun, 7.62-MM, M73 Tank.



